

OPERATING MANUAL

FOR

DTX 2400W SERIES POWER SUPPLY

DTX 2400W MODELS

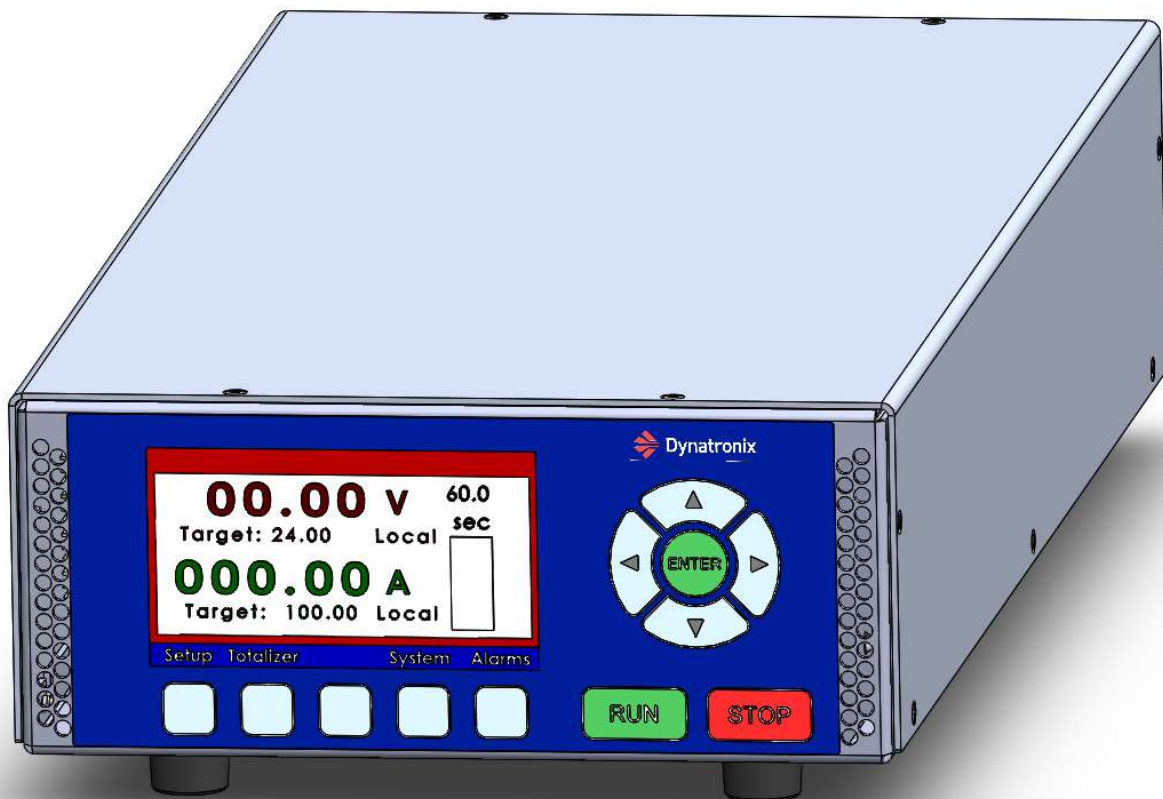

Table Of Contents

1. INTRODUCTION	3
1.1. TWO YEAR NEW PRODUCT WARRANTY.....	3
1.2. CONTACT INFORMATION.....	4
2. SAFETY PRECAUTIONS	5
3. FUNCTIONAL OVERVIEW	7
4. PRODUCT SPECIFICATIONS	8
5. INSTALLATION INSTRUCTIONS	10
5.1. POWER INPUT.....	10
5.1.1. <i>Input Power Requirements</i>	10
5.1.2. <i>Input Power Connection</i>	10
5.1.3. <i>Output EMC Filter Installation</i>	10
5.2. MOUNTING.....	11
5.3. OUTPUT POWER CONNECTIONS.....	12
5.3.1. <i>Standard Output Power Connections</i>	12
5.3.2. <i>Alternate Output Power Connections</i>	14
5.4. DB25 – EXTERNAL USER CONNECTIONS.....	15
5.4.1. <i>Inhibit Signal Connections</i>	16
5.4.2. <i>Digital Input / Output Connections</i>	17
5.4.3. <i>Analog Input/Output Connections and Configuration</i>	18
5.4.4. <i>Analog Calibration</i>	18
6. OPERATING PROCEDURES	19
6.1. FRONT PANEL CONTROLS.....	19
6.1.1. <i>LCD Display</i>	19
6.1.2. <i>Menu Navigation and Enter Pushbuttons</i>	19
6.1.3. <i>LCD Screen Specific Pushbuttons</i>	20
6.1.4. <i>Run Pushbutton</i>	20
6.1.5. <i>Stop Pushbutton</i>	20
6.2. DTX SERIES USER INTERFACE MANUAL.....	20
7. MAINTENANCE	21
7.1. CLEANING.....	21
REVISION HISTORY	22

1. Introduction

1.1. TWO YEAR NEW PRODUCT WARRANTY

DYNATRONIX, INC., hereby warrants to the purchaser that all new products sold are guaranteed against defects in materials or manufacture for **two years** after shipment. DYNATRONIX, INC., expressly reserves the right to offer an extended warranty at its sole discretion. Such express warranty shall not be deemed effective unless expressly authorized by DYNATRONIX, INC., personnel. DYNATRONIX, INC., at its sole discretion, will repair or replace any defective products that are returned in accordance within the time period proscribed by this warranty.

All products for repair or examination must be returned to DYNATRONIX, INC., prepaid. The defective product, as repaired or replaced, requires the issuance of a Return Material Authorization Number ("RMA") from DYNATRONIX, INC., personnel prior to acceptance for repair or replacement by DYNATRONIX, INC. An RMA will be issued upon determination by DYNATRONIX, INC., personnel that the defective product requires factory repair. The customer assumes all shipment expenses of the returned product to and from DYNATRONIX, INC., within the warranty period.

DYNATRONIX, INC.'s liability, under this warranty, shall in any event not exceed the original purchase price of the product. To make a claim under this warranty, it is the responsibility of the purchaser to immediately contact DYNATRONIX, INC., and provide proof of the product's model, part number, input and output voltage and serial number. DYNATRONIX, Inc., will then determine whether the product remains under warranty.

This warranty **DOES NOT COVER** failures caused by any of the following:

1. Misuse, negligence or accident;
2. Alterations made by individuals or parties not directly employed by DYNATRONIX, INC.

This warranty **DOES NOT EXTEND** to commercial sub-assemblies that are guaranteed by a manufacturer's warranty.

This warranty becomes effective upon the date the product is shipped. In the event that a product no longer covered by the NEW PRODUCT WARRANTY is sent for repair, the provisions of the REPAIR WARRANTY as detailed below govern.

DYNATRONIX, INC., EXPRESSLY DISCLAIMS ALL OTHER WARRANTIES, INCLUDING, WITHOUT LIMITATION, ALL EXPRESS WARRANTIES, THE IMPLIED WARRANTY OF FITNESS FOR A PARTICULAR PURPOSE AND THE IMPLIED WARRANTY OF MERCHANTABILITY. THERE ARE NO WARRANTIES WHICH EXTEND BEYOND THE DESCRIPTION ON THE FACE HEREOF.

REPAIR WARRANTY

DYNATRONIX, INC., hereby warrants to the purchaser that products previously purchased as new from DYNATRONIX, INC., and returned to DYNATRONIX, INC., for repair or replacement be hereby governed by the provisions of the REPAIR WARRANTY. DYNATRONIX, INC., expressly reserves the right to extend the REPAIR WARRANTY to products not purchased from DYNATRONIX, INC., at its sole discretion. The REPAIR WARRANTY shall exclude all products not purchased from DYNATRONIX, INC., unless expressly authorized by DYNATRONIX, INC., personnel.

DYNATRONIX, INC., guarantees that all repairs be free from defects for ninety (90) days after return shipment to purchaser. Product failures not related to repairs done by DYNATRONIX, INC., shall not be covered by the REPAIR WARRANTY. DYNATRONIX, INC., further warrants that repair investigations that fail to identify product defects shall be guaranteed for a ninety (90) day period after return shipment to customer. In the event that the product fails within the stated ninety (90) day period after the inspection, DYNATRONIX, INC., agrees to assume the in-out freight costs for subsequent returns of the product, experiencing the complained of problem, for an additional ninety (90) day period.

Effective Date: January 1, 2006

1.2. Contact Information

Contact Information	
Corporate Headquarters	
Process Technology 38809 Mentor Avenue Willoughby, OH 44094	Telephone: (440) 974-1300 Toll Free: (800) 621-1998 www.processtechnology.com
Technical Support :	Telephone: (440) 974-1300 Toll Free: (800) 621-1998 techsupport@process-technology.com Contact Us at Process Technology: processtechnology.com/contact-us-advanced.php

2. Safety Precautions

Before proceeding any further through this manual, this section should be read thoroughly to protect yourself and your equipment.

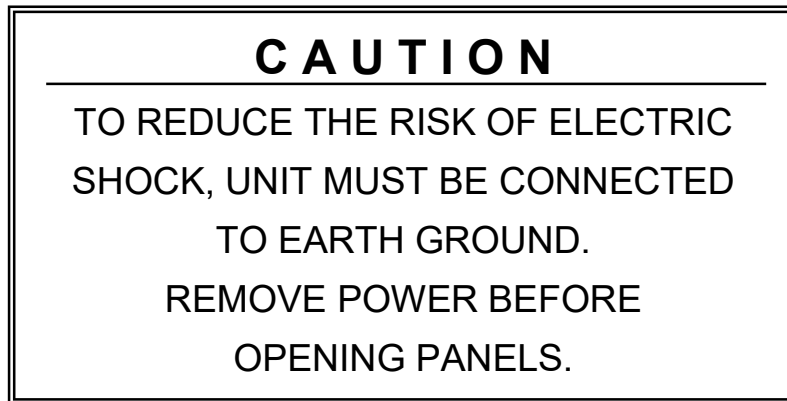

1. To properly operate this power supply, only electric cords with a 3-prong grounded system are to be used.
2. The electric cord providing power to the machine should be plugged in only to a grounded outlet that complies with U.L. and/or OSHA safety requirements, or local regulations.
3. If necessary to work inside the cabinet, remember to remove AC power before opening any panels. Not doing so may endanger yourself and your equipment. The means of disconnecting the power supply is either the removal of the detachable power supply cord from the power inlet or power receptacle or both. If the power cord is direct connected to the AC source as well as the power supply, turn off the local safety or power panel branch breaker which provides AC to the power supply. Follow your lock out / tag out procedures to ensure that power is not unexpectedly applied while servicing.
4. This unit contains no user serviceable parts. All repairs or modifications to this unit must be done at the Dynatronix factory, or at an authorized Dynatronix Service Center, or by a qualified service technician. See the Table of Contents section for a list of authorized service centers in the USA and Europe.
5. Caution: When AC power is applied, high voltages (both AC and DC) are present inside the cabinet. All repairs must be done by a qualified service technician.
6. If the equipment is used in a manner other than mentioned in this manual, the protection provided by this equipment may be impaired.

7. This symbol indicates a protective earth connection.

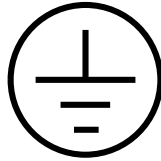

8. This symbol means to consult the product manual for additional information.



9. This label indicates where high AC or DC voltages are located inside of the unit. Be aware of these locations if power is needed for any work being done inside of unit. Not doing so may endanger yourself and your equipment.

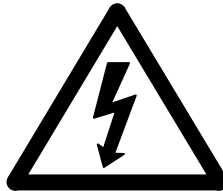

10. This label indicates where components or surfaces are operating at temperatures which might cause injury either directly (burn) or indirectly (involuntarily moving body into another danger). This label is used most often on the output transistor heatsinks.



11. If this power supply weighs more than 40lb / 18kg (see Section 4 - Specifications), it must be lifted by two persons. Always use proper lifting technique.

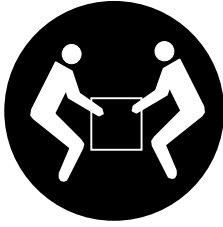

12. Use of this product for purposes other than those specified in this manual is not recommended. Use for other purposes may give unexpected results or cause damage to the power supply and/or the system it is being used in.

3. Functional Overview

The DTX 2400W series plating power supply is a compact, high power unit that offers a wide range of features for the plating industry. It has universal power input with power factor correction. The power supply has a sealed design with a fan cooled heat sink tunnel. The unit is packaged in a ½ rack sized enclosure.

The DTX comes with a user interface. The user can set and monitor the voltage and current and there are indicators for errors and status of the unit. The settings are changed using the front panel keypad. The encoders have pushbutton switches for changing the meter display from the readings to the settings for visual adjustment of the set point. By using the proper settings the power supply can be set to run in current, voltage or crossover regulation modes.

The DTX user interface contains menus that allow various features to be configured and provide for display of information regarding cycle status.

The DTX supports the following features

- Manual Cycle Control
- Real Time Cycle Control (RTC)
- Amp Time Cycle Control (ATC)
- User Configurable Totalizer
- Over Temperature Shut down
- Remote operate/standby control (isolated digital input)
- Digital Outputs; Alarm, Operate
- Digital I/O; Spare1, Spare 2
- Optional analog control (4-20mA, 0-10V)
- Digital Calibration
- Alarms and diagnostics
 - Tolerance
 - Power failure
 - Over temperature shut down
 - Various System diagnostics

4. Product Specifications

PRODUCT SPECIFICATIONS						
INPUT POWER	100-240VAC, 50/60Hz, single phase @ 1200W 208-240VAC, 50/60Hz, single phase @ 2400W					
INPUT PROTECTION and INPUT CURRENT RATING	Main: The input is protected by two internal fuses.					
	MODEL	MAXIMUM INPUT CURRENT RATING (RMS) AT NOMINAL LINE VOLTAGES (60 HZ) *Derated to 1200W				
		90VAC/50Hz	100VAC	115VAC	208VAC	230VAC
	DTX12-10		1.5A	1.5A	1A	1A
	DTX12-50		7A	6A	4A	3A
	DTX18-25		6A	5A	3A	2A
	DTX24-10		3A	2A	1.5A	1A
	DTX24	*15A	*14A	*12A	13A	12A
	DTX48	*15A	*14A	*12A	13A	12A
DTX100	*15A	*14A	*12A	13A	12A	
OUTPUT RATING	MODEL	MAX RATED VOLTAGE	MAX RATED CURRENT	MAX RATED POWER		
	DTX12-10	12V	10A	120W		
	DTX12-50	12V	50A	600W		
	DTX18-25	18V	25A	450W		
	DTX24-10	24V	10A	240W		
	DTX24	24V	100A	2400W		
	DTX48	48V	50A	2400W		
	DTX100	100V	24A	2400W		
POWER FACTOR	0.99 typical at 115 and 230VAC.					
LINE REGULATION	Input voltage variations over the full input voltage range, with constant load conditions, will not cause variations in the power supply output that exceed the specified values.					
	Output Voltage: Greater of $\pm 1\%$ of setting or $\pm 0.1\%$ of the maximum voltage rating for the power supply.					
	Output Current: Greater of $\pm 1\%$ of setting or $\pm 0.1\%$ of the maximum current rating for the power supply.					
LOAD REGULATION	Load variations from 10% to 100%, with constant line conditions, will not cause variations in the power supply output that exceed the specified values.					
	Output Voltage: Greater of $\pm 1\%$ of setting or $\pm 0.1\%$ of the maximum voltage rating for the power supply.					
	Output Current: Greater of $\pm 1\%$ of setting or $\pm 0.1\%$ of the maximum current rating for the power supply.					
OUTPUT PROTECTION	The internal controller will not accept commands that will exceed the output rating of the power supply.					

CONTROLS	DTX Front panel (display and keypad). Ethernet for remote Host control. Optional Analog Interface.
METER ACCURACY	Within the greater of +1% of the actual voltage or current output or $\pm 0.1\%$ of the maximum current rating for the power supply plus one least significant digit.
ENVIRONMENTAL CONDITIONS	INDOOR USE ONLY Operating temperature: 0 - 40C Non-condensing humidity conditions 20-80% RH Storage temperature: -20 - 70C
RMS NOISE, HUM, RIPPLE, DROOP	$\leq 1\%$ of peak output rating from 10 to 100 % of full rated output.
COOLING	Forced air cooling: in through front, out through rear. Input cooling air is isolated from the electronic circuits of the power supply. Allow 2 inches (51mm) minimum clearance on front and rear of unit.
ENCLOSURE	Half-rack enclosure, Aluminum, Powder Coat Paint.
SIZE	3.43" (87.1mm)H x 8.45" (214.6mm)W x 20" (508mm)D 20" (508mm)D including controls and connectors. 18" (457mm)D chassis.
WEIGHT	Approximately 11lbs (5kg).

5. Installation Instructions

5.1. Power Input

5.1.1. Input Power Requirements

The input power and output capacity of each model is specified on the equipment serial tag located on the back of the unit. The power supply has a universal input, 100-240VAC, 47-63Hz, single phase. Derate maximum output power to 1200W for input voltages from 100-208Vac.

5.1.2. Input Power Connection

Make sure the Main Power Switch is in the OFF (0) position. The AC input receptacle accepts power cords with IEC60320 C19 type connector. The power cord should be capable of 20A and rated for 250VAC. Plug the female end of the power cord into the back of the power supply. Connect the male end of the power cord* to the correct supply in accordance with U.L. and/or OSHA specifications. Do not replace the detachable mains supply cord with an inadequately rated power cord.

*If power supply does not come equipped with a male plug, use Interpower NEMA 6-20 (250Vac, 20A) P/N: 88030180 or equivalent.

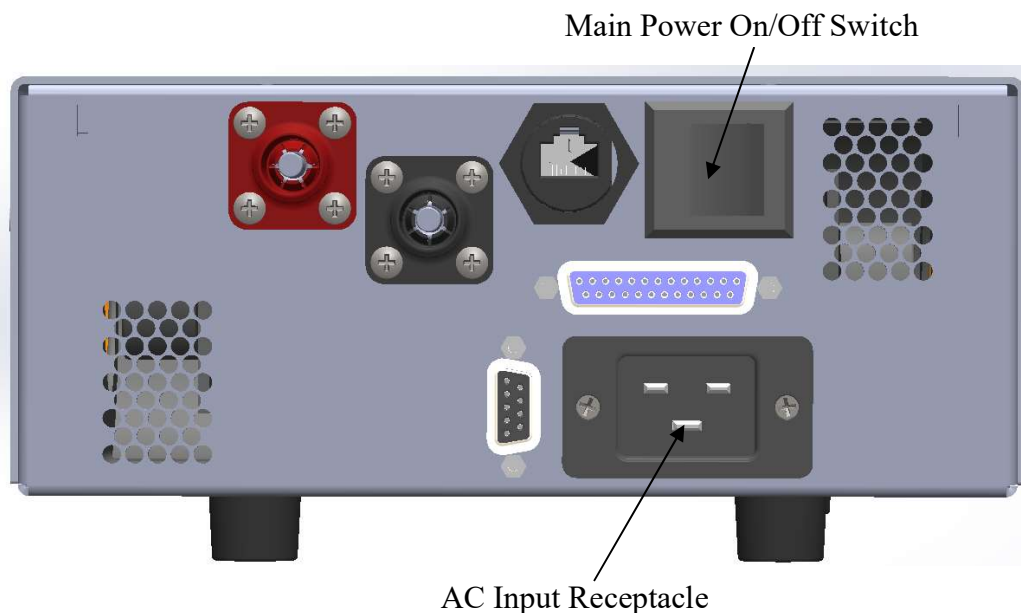

The main power On/Off switch applies power to the unit. Do not position the equipment so that it is difficult to operate the power On/Off switch.

5.1.3. Output EMC Filter Installation

For EMC compliance add the following supplied cores to the communication outputs:

- ENET - Install FAIR-RITE core 0431164181 with 2 turns (Dynatronix p/n 031-0041-09)
- DB25 wire - Install FAIR-RITE core 0431164181 with 1 turn (Dynatronix p/n 031-0041-09)

5.2. Mounting

Place the DTX 2400W Series power supply on a shelf capable of accepting a 1/2 rack mount package.

Cooling is from front to rear. Do not block airflow to the unit. Leave at least 2 inches (5cm) in front of and behind the power supply for adequate ventilation. Place the unit in an area which has adequate ventilation to prevent condensation. Do not spray liquids on or inside power supply. Keeping units away from corrosive plumes will help prolong the life of your capital investment. Do not position the equipment so that it is difficult to operate the power on/off switch (located at rear).

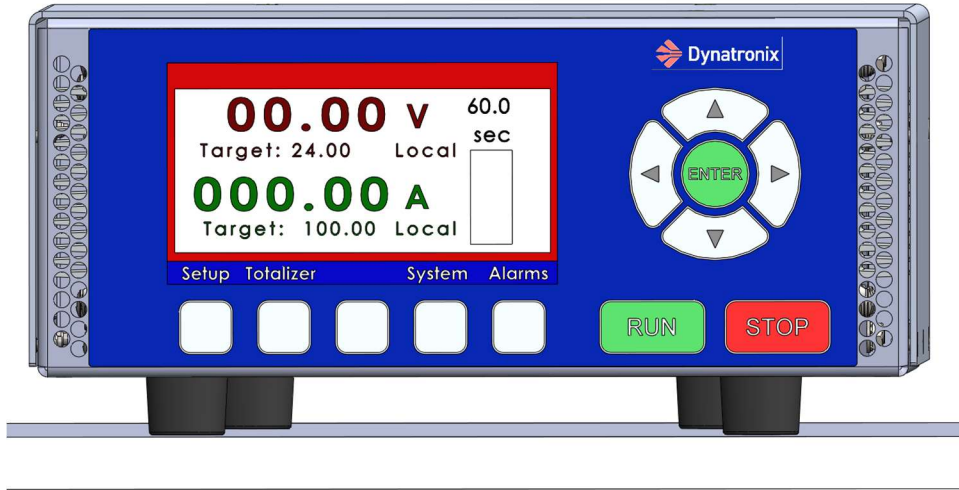

The DTX has a bail mounting option which allows the DTX front panel to be offset from the top of the mounting surface by approximately 2.5". Contact Dynatronix for ordering information.

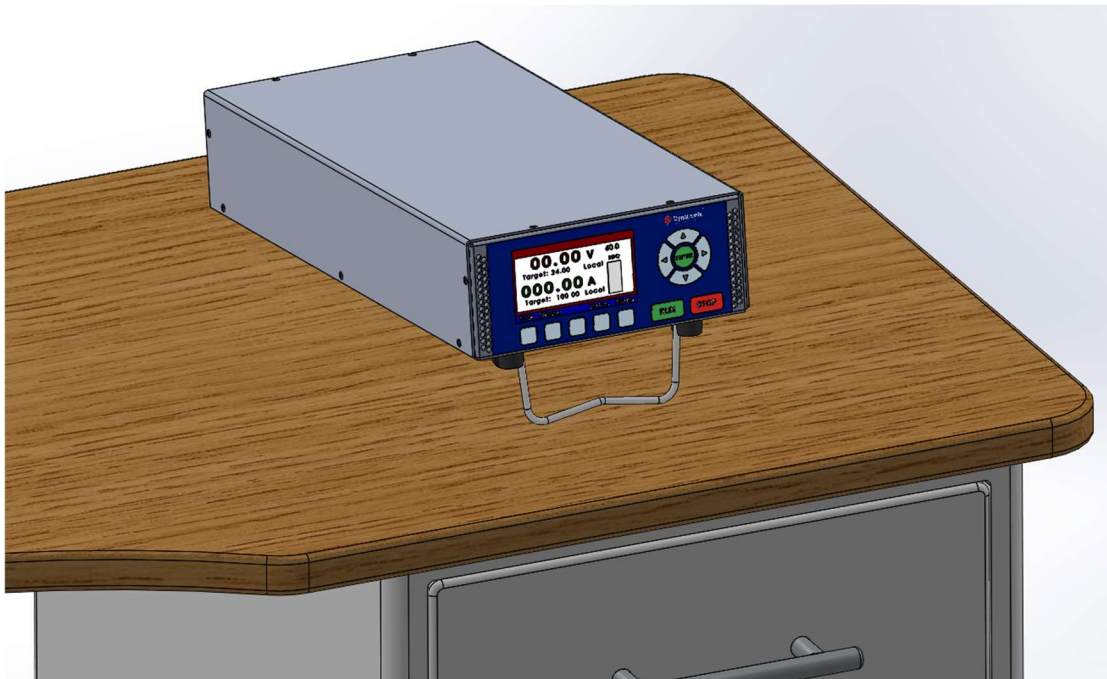

Optional Swing Out Bail

5.3. Output Power Connections

5.3.1. Standard Output Power Connections

Located at the rear of the DTX 2400W Series are two high current connectors which are used to connect to the bath. The mating connectors consist of compression lugs (supplied) which have a locking mechanism when mated. Make sure compression lugs are properly crimped to reduce heating. Loose crimps could damage the power supply. Also, make sure the output wiring is of the proper AWG to handle the output current and has an insulation rating greater than 100V.

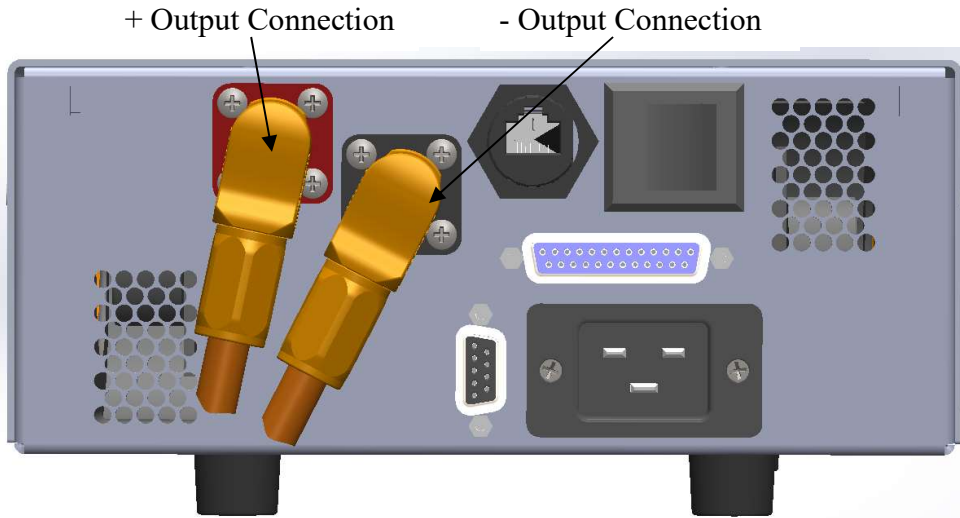

Output Connector Compression Lug	Dynatronix Part Number	Amphenol Industrial Part	Max. Wire Size mm ² , AWG
Red	024-0694-01	SLPPA25BSR	25mm ² , 4 AWG
Black	024-0694-00	SLPPA25BSB	25mm ² , 4 AWG

Amphenol Industrial is the manufacturer of these compression lugs (See part no above). For crimping, Amphenol recommends a hydraulic battery terminal crimper set (See next page). Recommended crimper set is available through Dynatronix by ordering part no. 174-0011-00.



https://www.amazon.com/Hydraulic-Battery-Terminal-Crimper-Crimping/dp/B00GXQ2E5E/ref=pd_sim_60_3?ie=UTF8&dpID=51

https://www.amazon.com/TEMCo-Hydraulic-Cable-Crimper-TH0006/dp/B00HJXH1K/ref=pd_sim_sbs_469_9?ie=UTF8&dpID=41lg

Surlok+ Plug Crimp Instruction

Fix the Surlok+ in the right position of the crimp tool as shown below, then crimp the cable to meet the pull force requirement:



Manual Crimp



Machine Crimp

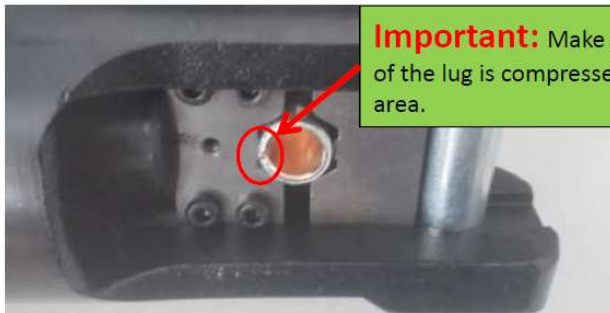

Reversed View

Important: Make sure the close line of the lug is compressed in the flat hex area.



Crimped View

Recommended Manual Crimp Die Design:

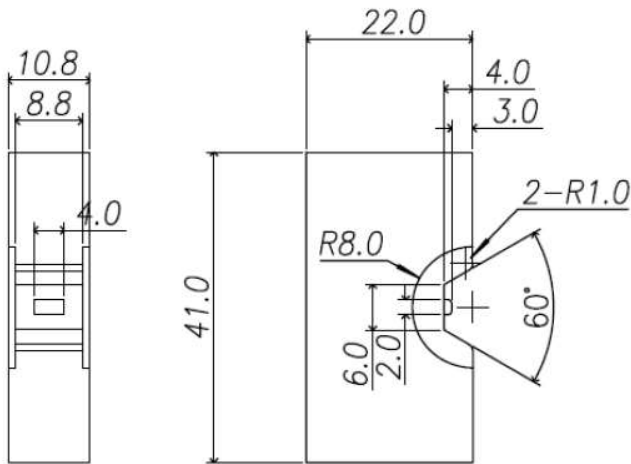

25mm²/16mm² Crimp Die/ Pull force 623N min.

5.3.2. Alternate Output Power Connections

Instead of the standard crimp terminal connections (See section 5.3.1) for the positive and negative output, an alternate output power connection is available which consists of 1/4-20 UNC threaded studs including associated washers and wing nuts. Make sure the 1/4 ring lugs used in this output connection configuration are properly crimped and tightened to reduce heating. Loose crimps or connections could damage the power supply. Also, make sure the output wiring is of the proper AWG to handle the output current and has an insulation rating greater than 100V.

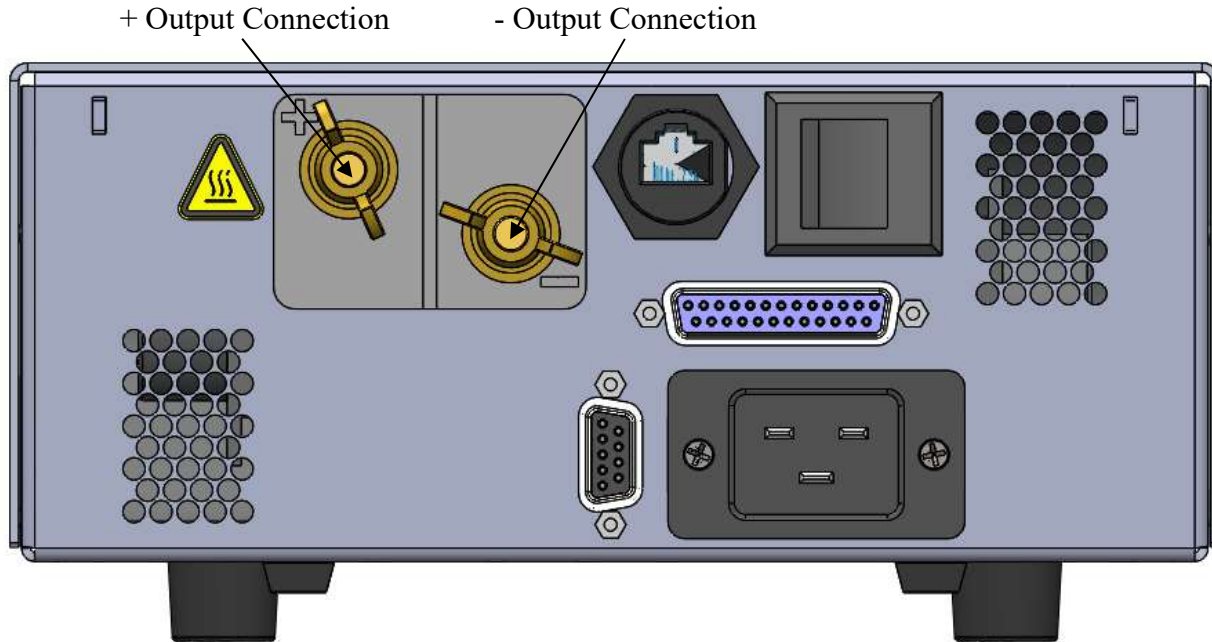

Note: These alternate output power connections are currently not available on the DTX100 model.

5.4. DB25 – External User Connections

DB25 – External User Connections

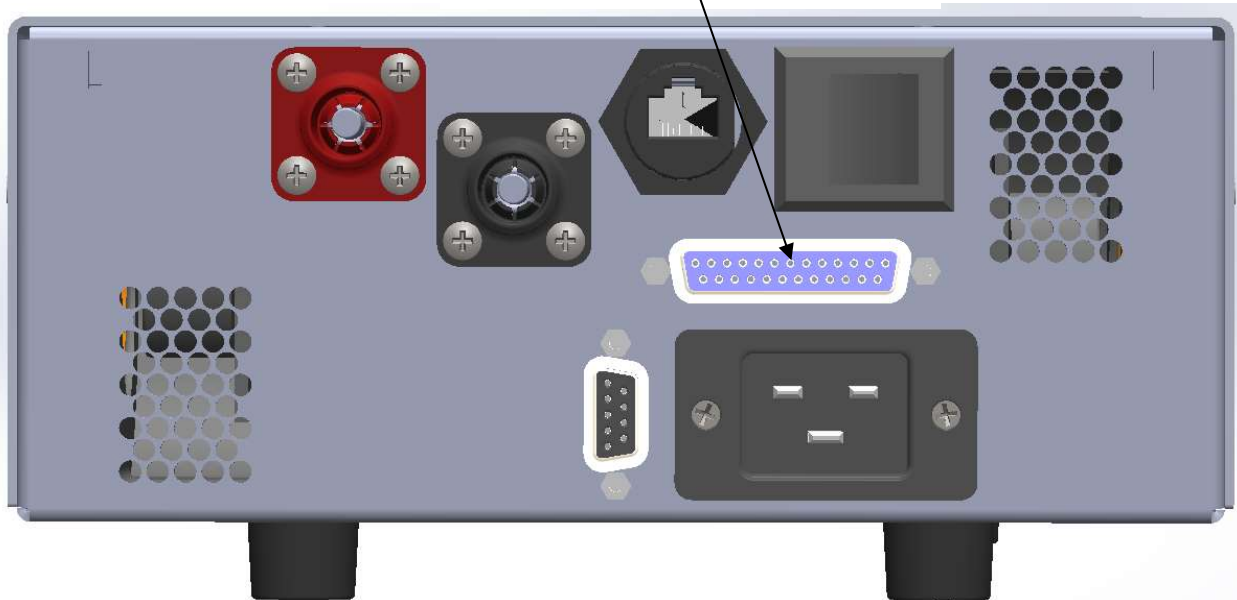

A DB25 solder cup type mating connector and housing is supplied with the standard DTX model and used for external customer connections. See picture below.

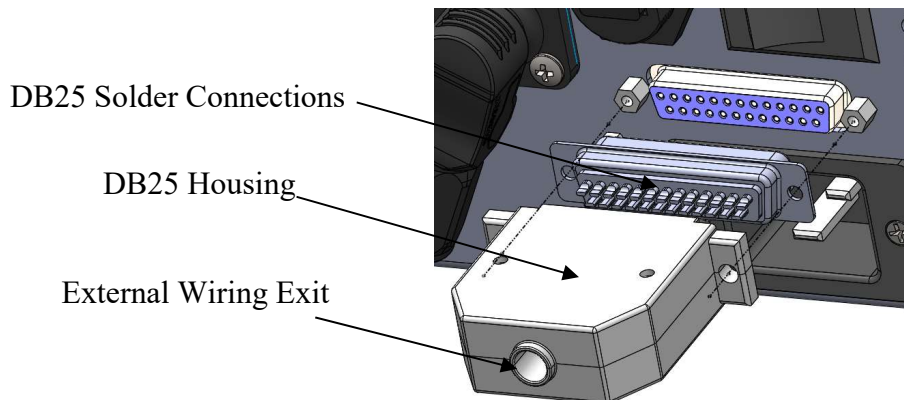

An alternate 25-pin D-type adaptor is available which has screw type connections instead of solder. It can be assembled with the external wiring exit to the left or right. To better accommodate the DTX series, it would be better to assemble it to the right as shown below. For ordering information, the ProTec Dynatronix internal part no. is 024-0419-25.

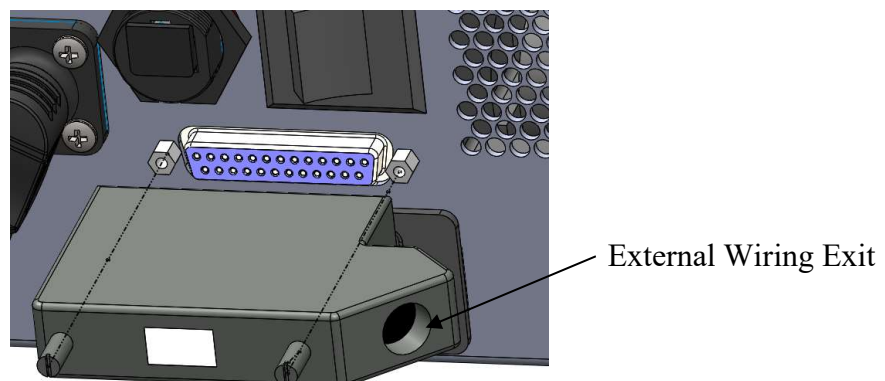

5.4.1. Inhibit Signal Connections

Located on the DB25 connector are the Inhibit Signal connections. When the inhibit input is active the power supply output is disabled and the front panel “inhibit” LED illuminates. The inhibit signal can be used for a safety interlock or as a remote operate/standby control. The inhibit signal can be a switch closure or a voltage signal input depending on how the inhibit terminals are wired (see the diagram below). If the inhibit signal is not used pins 3 and 15 must be connected with a jumper wire to enable power supply operation. The external wiring for the inhibit signal should be capable of handling a maximum current of 10mA have an insulation rating greater than 100V.

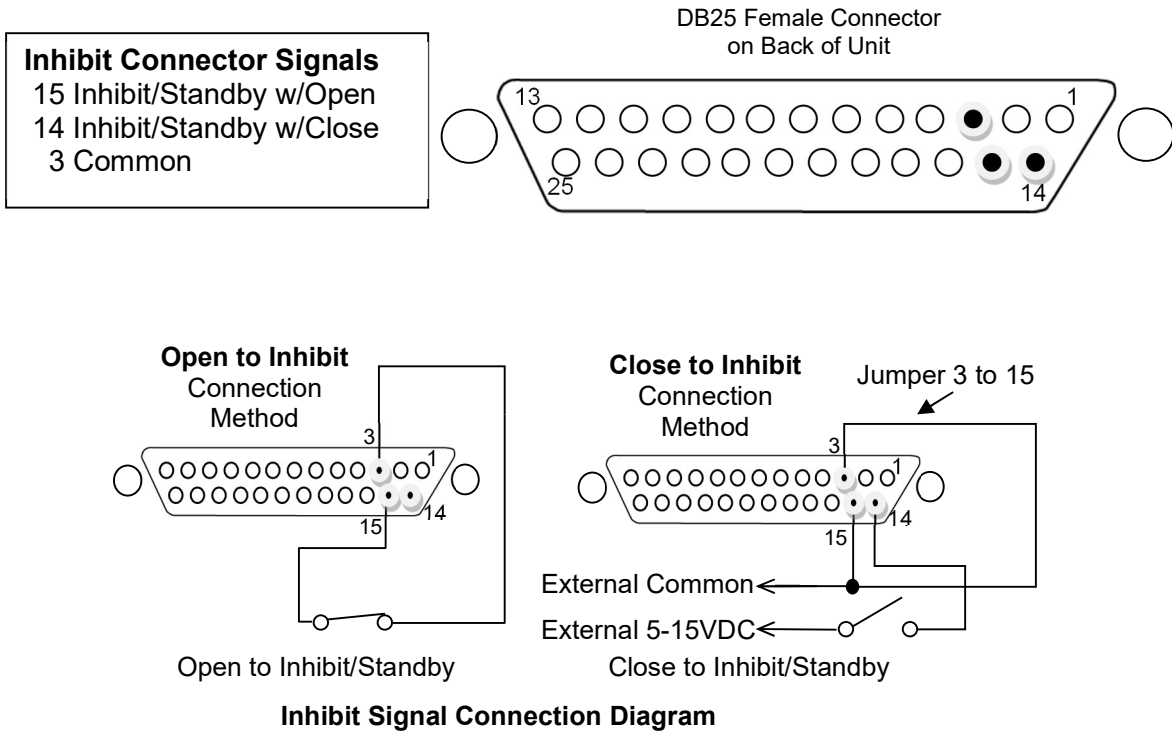

5.4.2. Digital Input / Output Connections

Located on the DB25 connector are connections for six Digital Inputs/Outputs. There are two standard Digital Outputs and one standard Digital input defined. There are three undefined (Spare) Digital input/outputs for future implementation.

The standard Digital Outputs include Alarm (Pin 18) and Operate (Pin 5) indicators. Both digital outputs have 10.0K pull-up resistors to an internal +5V. When the signal is active (Alarm or Operate) the corresponding output transitions from +5V (or input level) to common (0V), when referenced to the Input/Output Common (Pin 6 or 12). The Digital Inputs can sink a maximum of 200mA of current.

The only currently defined standard Digital input is Operate (Pin 4). The Operate Digital input has an internal 10.0K pull-up to +5V. When this input is connected to i/o common (pin 6 or 12) the unit will go to the Run state. The unit will remain in Run until the connection is opened unless there is an Amp-Time Cycle (ATC) or Real-Time Cycle (RTC) running in which case the unit will go to the stop state when the cycle time is complete (or the connection is opened). When an ATC or RTC is set the input must be opened and closed to start a new cycle.

The external wiring for the Digital inputs and outputs should be capable of handling a minimum current of 200mA and have an insulation rating greater than 100V.

Digital I/O Connections	
16	- Spare 1 Input/Output
17	- Spare 2 Input/Output
9	- Spare 3 Input/Output
4	- Operate Input
5	- Operate Output
18	- Alarm Output
6	- Input/Output Common
12	- Input/Output Common
24	- 24V Supply, 20mA Max

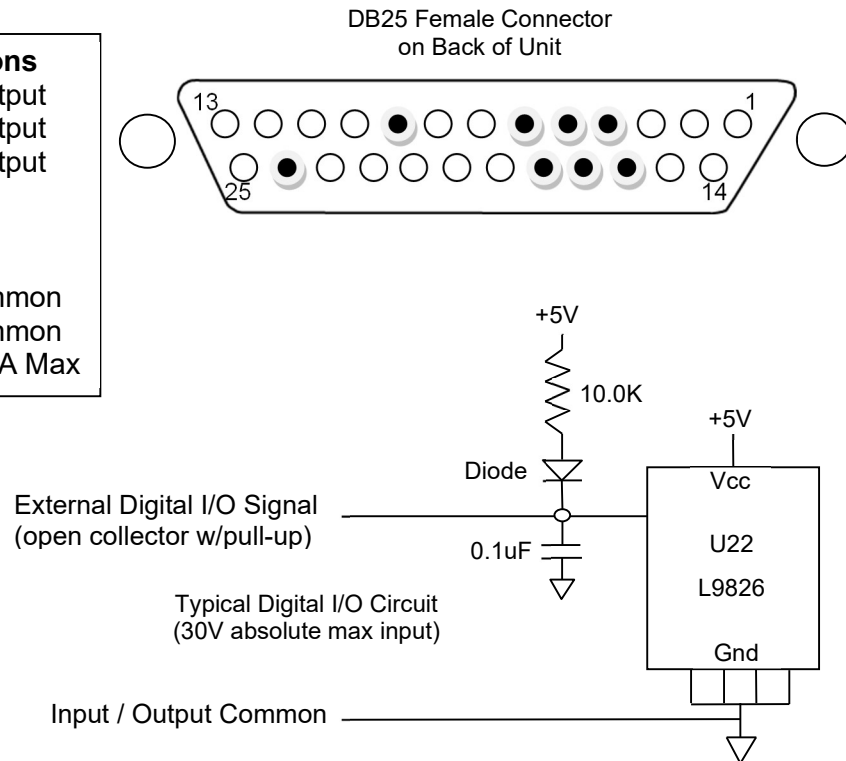

5.4.3. Analog Input/Output Connections and Configuration

The DB25 Input/Output connector has connections for 2 Analog Inputs and 2 Analog Outputs.

The channel Type is selectable between 4-20mA and 0-10V control. The selection is made using the [System] and then the [Control] soft keys. Select Control Mode: Analog and [Save]. Then set the control Type: for each channel, 4-20mA or 0-10V. Set the Source: to Analog. If only driving one of the settings, current or voltage, then set the other one to "Rating" so that analog input does not need to be driven. Press [Save] and then [Cancel] to save and exit the menu.

Analog channel 1 is for current setting and reading and Analog channel 2 is for voltage setting and reading. Note that the analog output readings are always active, even when the analog control mode is not selected (they do need to be set to the desired Type: if used).

The analog inputs and outputs are isolated from the control section of the power supply but not from each other. Only the used inputs and outputs need to be connected to the controller.

The diagram below shows how to make connections to the DTX power supply for analog control of both current and voltage, settings and readings.

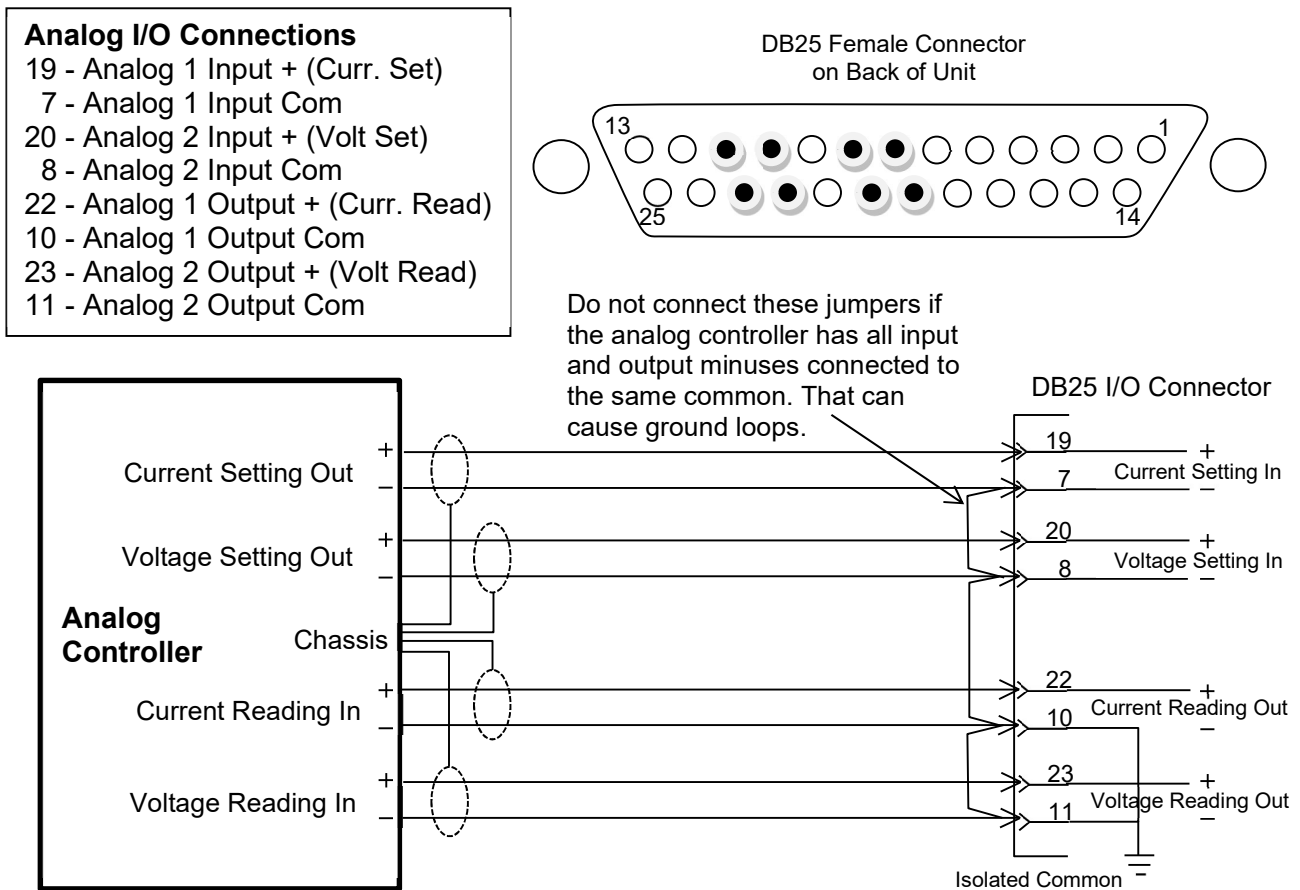

5.4.4. Analog Calibration

Analog calibration is done through the menus on the DTX Main Screen.

Select the [System] and then the [Control] soft keys. Select Control Mode: "Analog" and [Save]. Then set the desired control Type: for each channel and make sure both Source: settings are set to Analog. Press [Save]. Follow the [Help] menu and the hints at the bottom of the screen and the green highlighted lines to calibrate the analog interface.

6. Operating Procedures

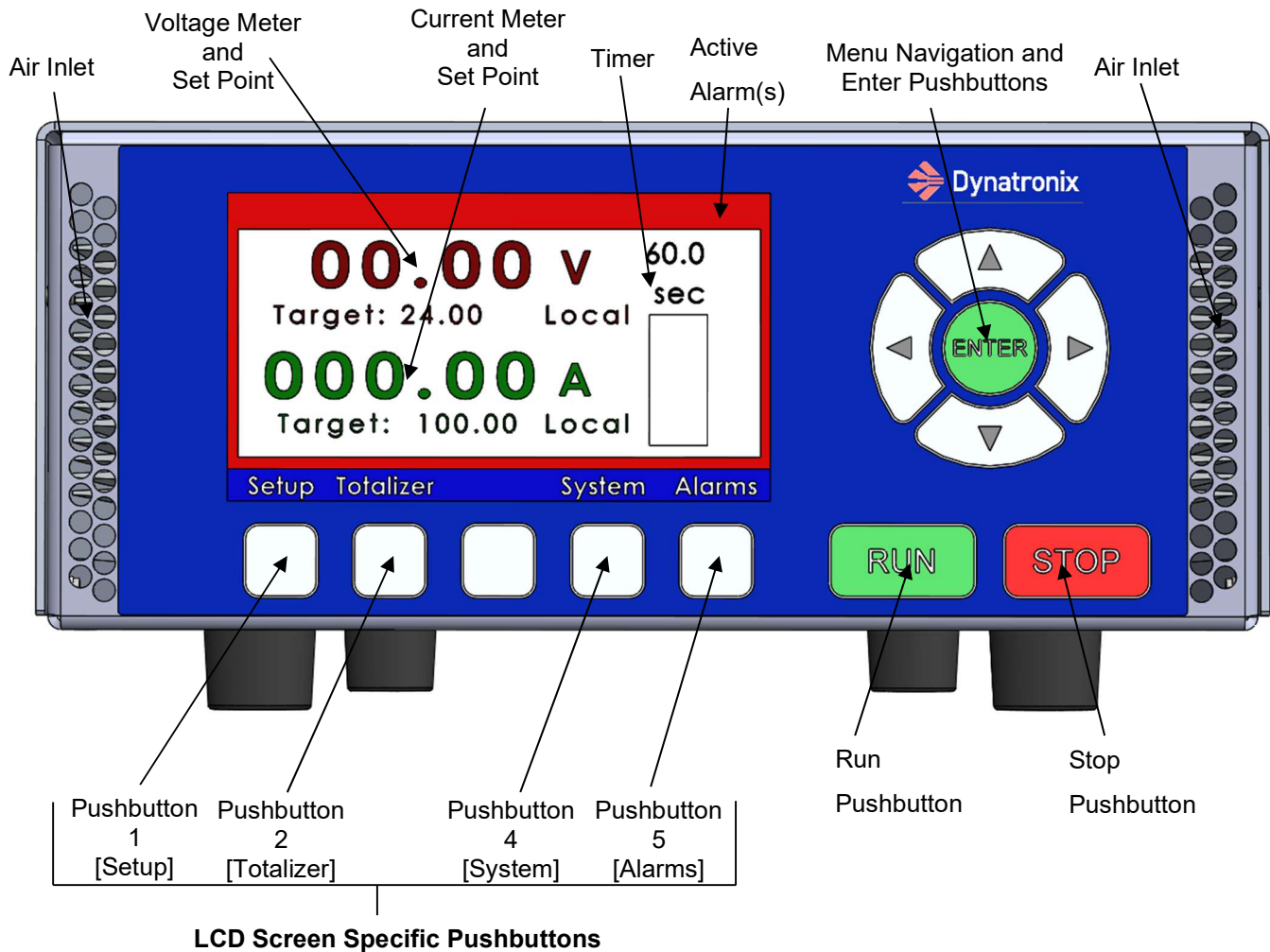

Figure 6-1 Typical Power-up Front Panel Display (Home Screen)

6.1. Front Panel Controls

6.1.1. LCD Display

In addition to providing output settings (target) and output readings, the LCD display also identifies the function of the five pushbutton switches located directly below the display. When in a specific screen, if a pushbutton does not have a title displayed directly above it, then that pushbutton is not active in that screen. Pressing a pushbutton with a Title above it will access the screen associated with that pushbutton's function.

6.1.2. Menu Navigation and Enter Pushbuttons

The menu navigation consists of up, down, left and right arrow pushbuttons which are typically used to move the cursor left and right in the display and change settings using the up and down pushbuttons. The center Enter pushbutton is used to switch between parameters – Current Target, Voltage Target and Timer duration.

6.1.3. LCD Screen Specific Pushbuttons

As stated previously in Section 6.1.1 LCD Display, the five pushbuttons located below the LCD Display are used to access sub-screens such as [Setup](#), [System](#) and [Alarms](#).

6.1.4. Run Pushbutton

The green RUN pushbutton is used to enable the output of the power supply. In the RUN mode the output of the supply is enabled and will output current depending on the settings. The border of the LCD screen will change to the color green when in the RUN mode.

6.1.5. Stop Pushbutton

The red STOP pushbutton is used to disable the output of the power supply. The border of the LCD screen will change to the color red when in the STOP mode. Pressing the STOP pushbutton while a timed cycle (ATC or RTC) is running will stop the currently running cycle (output disabled).

6.2. DTX Series User Interface Manual

See 198-1007-03 – DTX Series User Interface under separate cover for information on specific screens.

7. Maintenance

7.1. Cleaning

The exterior of this power supply may be cleaned using a damp cloth and a water/detergent solution.

Clean air inlet and air exit as needed to prevent build-up of debris using compressed air or a vacuum.

Do not allow an excess build-up of dust and debris to accumulate on the unit as the power supply may run hotter and signal an over-temperature alarm or go into standby mode.

Failing to follow cleaning and maintenance procedures may void the warranty and reduce the life of the power supply.

Revision History				
Rev	Description	ECO	Date	Initials
01	Start with 198-0853-02 Rev F.		05/17/17	TAM
02	Updated Section 5, DB25 connections for change to OEM cable and to specify greater than 100V insulation requirement for external wiring. Add input current rating to section 4. Edited Section 2 Safety Precautions, Para 5. Add note to Installation Instructions, Section 5.2 to not position the equipment so that it is difficult to operate the power on/off switch. Update pictures.		08/01/17	TAM
03	Updated Section 5. Removed Appendix.		08/09/17	TAM
04	Deleted the following sections that do not apply or are not defined - Remote Host and Analog Control, Calibration Procedure, Optional Features and Controls.		08/23/17	TAM
05	Added timer to display screen. Added bail mounting option to Section 5.2 Mounting		08/24/17	TAM
06	Added 90VAC/60HZ max current draw to spec section.		08/29/17	TAM
07	Changed max current draw in spec section.		08/29/17	TAM
08	Added analog control setup note to installation section. Removed Host Port Connection section. Changed Inter-Module connection.		10/10/17	PJB
A	Production release	REL1230	11/6/17	NPK
B	Changed digital i/o definitions for software versions 231-V010303, 208-V010503, 628-V0019. Add diode and capacitor to digital i/o. Added 1 extra digital i/o. Added analog i/o section. Update line and load regulation sections and meter accuracy section.	REL1272	3.14.2018	PJB
C	Added cores on communications wires for EMC compliance in section 5.1.3	REL1285	4/18/18	NPK
D	Added section 5.3.2, alternate power output connections and modified the first page of section 5-4 to indicate standard and alternate DB25 connectors.	REL1323	9/13/18	TAM
E	Added models DTX18-25 and DTX24-10 to Section 4, Product Specifications.	DCR166	10/22/19	TAM
F	Update DTX features list in Section 3, Update Contact Information.	DCR428	9/29/20	TAM
G	Removed section 5.4.1 Remote voltage sense. Removed mention of Ferrite Core on DB9 cable	DCR756	9/9/22	GAM

THIS DOCUMENT IS THE PROPERTY OF DYNATRONIX INC AND MAY NOT BE REPRODUCED OR USED IN ANY MANNER WIHTOUT PERMISSION OF DYNATRONIX INC.