

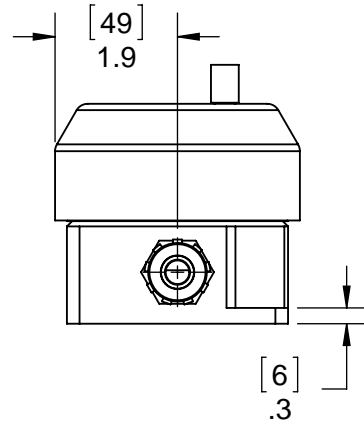

RBA08 Dimensions

Dimensions: [mm] in

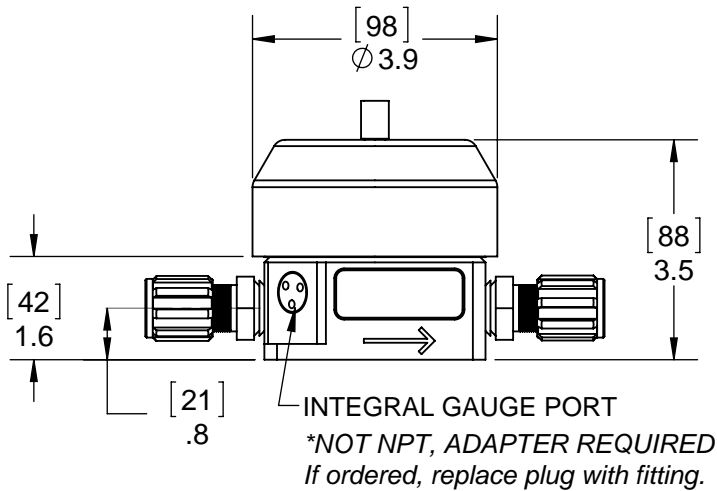
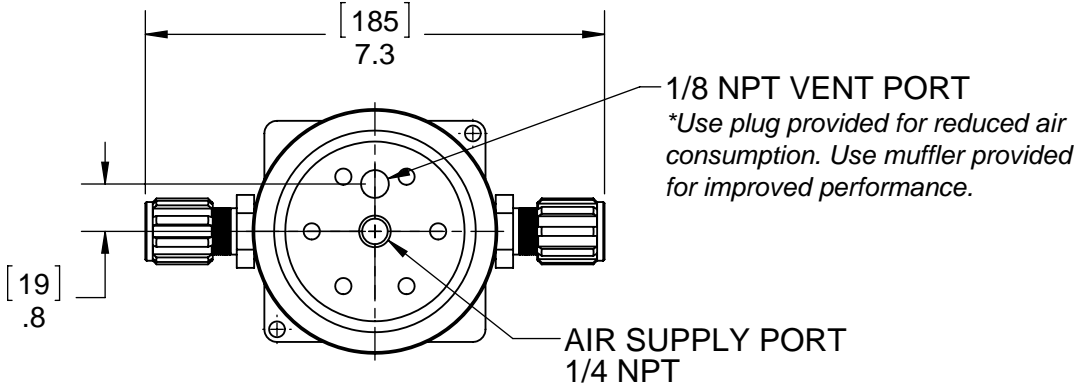

MOUNT WITH 2X 10-24 [M 5 x .8]
SOCKET HEAD CAP SCREWS

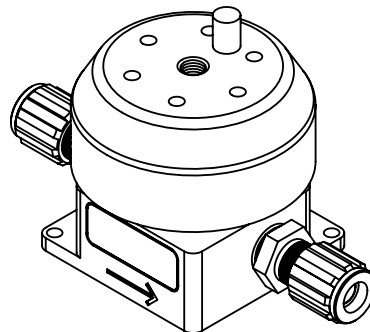
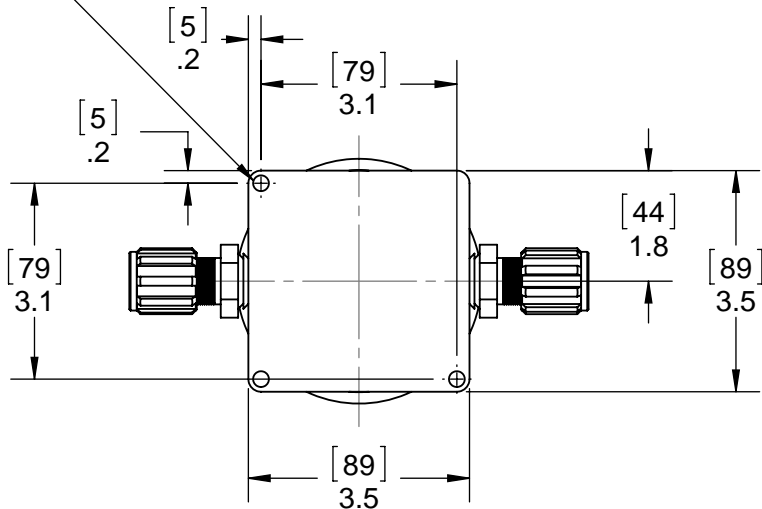

<https://wkfluidhandling.com/pressure-regulators/>

