

DSL/ T-DSL Instruction Manual



TABLE OF CONTENTS **DSL / T-DSL Digital Temperature Control**

| | | | |
|--|---|---------------------------------|----|
| Specifications..... | 1 | Programming | 7 |
| Model Number Identification..... | 3 | The home display | 8 |
| General Description | 4 | Menu Selections | 8 |
| Installation..... | 4 | Security Level Selections..... | 8 |
| Wiring..... | 5 | Primary menu..... | 9 |
| Over-temperature Protection..... | 5 | Secondary menu | 9 |
| Power and Relay Wiring..... | 6 | Secure menu..... | 12 |
| Wiring for 4-20 mA Transmitter Inputs | 6 | Alarm type and action..... | 18 |
| Wiring for Optional Inputs and Outputs | 7 | PID self tune function..... | 21 |
| Extending Wiring..... | 7 | Diagnostic Error Messages | 22 |



38809 Mentor Avenue • Willoughby, Ohio 44094 • Phone: 440-974-1300
USA/CN: 800-621-1998 • Fax: 440-974-9561 • www.processtechnology.com

COPYRIGHT 2019 Process Technology

DSL Specifications

| | |
|---|--|
| Standard Input | 2 wire 1000 ohm RTD TCR (alpha), 0.00385 ohm/ohm/°C RTD Self Heating Coefficient: 5° C/w in 0.2 m/s water; 200° C/w in 1 m/s air measurement current, 0.1 to 0.2 mA |
| Input Range | -328°F (-200°C) to 4208°F (2320°C), depending upon input type |
| Set Point Range | Selectable throughout the input range (see chart on page 2) |
| Sensor Break or Short Protection | De-energize control output to protect system after customer set time (see InPt setting in secondary menu) Note: No sensor short protection with Thermocouple sensor |
| Accuracy | ± 0.25% span, ± 1 digit |
| Enclosure | Front panel rating: Type 2, 3R, 4, 4X, 12, for indoor use only |
| Display | Two 4-digit, 7-segment 0.3" tall LED displays |
| Control Function | ON/OFF or PID |
| Control Outputs | <p>SP1 Set Point Relay: (reverse acting) SPST 3A resistive at 240 VAC max; 1.5A at 240VAC inductive; Pilot duty rating 240VA, 2A at 120VAC or 1A at 240VAC SSR: 2.0A combined outputs A & B at 240VAC at 25C (77F). Derates to 1.0A at 55C (130F)</p> <p>SP2 Set Point Relay: (direct acting) SPST 3A resistive at 240 VAC max; 1.5A at 240VAC inductive; Pilot duty rating 240VA, 2A at 120VAC or 1A at 240VAC SSR: 2.0A combined outputs A & B at 240VAC at 25C (77F). Derates to 1.0A at 55C (130F)</p> <p>Alarm Output Relay: SPST 3A resistive at 240 VAC max;</p> |
| ON/OFF Differential | Field adjustable, 1° (F or C) to 99° |
| Memory | Nonvolatile |
| Supply Voltage | 100 to 265 VAC, 50-400 Hz, 5VA |
| Operating Conditions | <ul style="list-style-type: none"> • Indoor Use Only • 20°F (-7°C) to 140°F (60°C) • Max Altitude: 3000m • Max Relative Humidity: 80% • Pollution Degree 2 • Installation Category II |

DSL Specifications, continued

Input Options

RTD 2 & 3-wire 100 ohm 0.00385 ohm/ohm/°C or
0.00392 ohm/ohm/°C

Thermocouples - (types J, K, T, R)

NIST Monograph 175, revision ITS-90 (Obsolete)

Current 4-20mA DC

Voltage (1-10 VDC)

Frequency (0-200 Hz, counts/second),
+/- 6 VDC p to p (up to 30VDC peak with Sw2 ON)

Output Options

4-20 mA DC proportional to the process (display) value.
Maximum impedance 450 Ohms.

☑ Equipment protected throughout by Double Insulation or Reinforced Insulation.

INPUT RANGES (Field Selectable)

Thermocouple Types

| | | | | |
|-------------------|-----------------------------------|---|----------------------------------|----------------------------------|
| Input Type | Type J or L* Iron + Constantan | Type K* Chromel + Alumel | Type T* Copper + Constantan | Type E* Chromel + Constantan |
| Range | -100 to +1600°F -73 to +871°C | -200 to +2500°F -129 to +1371°C | -350 to +750°F -212 to +398°C | -100 to +1800°F -73 to +982°C |
| Input Type | Type R PT 13% PT | Type S PT 10% PT | Type B PT 6% RE PT 30% RE | Type C W 5% RE W 26% RE |
| Range | 0 to 3200°F -17 to +1760°C | 0 to 3200°F -17 to +1760°C | +75 to 3308°F +24 to 1820°C | 0 to 4208°F -17 to 2320°C |
| Input Type | Type N* Ni Chr Si + Ni Si | * These Input Types can be set for 0.1° display. If temperature goes above 999.9° or less than -199.9°, the display will return to whole degree resolution. | | |
| Range | -100 to +2372°F -73 to +1300°C | | | |

RTD Types

| | | | | |
|-------------------|---|--|---|---|
| Input Type | 100 Ohm Platinum 0.00385 DIN Curve* | 100 Ohm Platinum 0.00392 Nist Curve* | 120 Ohm Nickel 0.00628 US Ind. Curve* | 1000 Ohm Platinum 0.00385 Nist Curve* |
| Range | -328 to +1607°F -200 to +875°C | -328 to +1607°F -200 to +875°C | -112 to +608°F -80 to +320°C | -328 to +1607°F -200 to +875°C |

Process Input Types

The 0 to 20 mADC, 4 to 20 mADC, 0 to 10 VDC, 2 to 10 VDC, and -10 to +10 mVDC inputs are fully scalable from a minimum of 100 count span placed anywhere within the range of -1999 to +9999. Decimal point position is adjustable from the zero place (9999), tenths (999.9), hundredths (99.99), thousandths (9.999), or ten thousandths (.9999).

Model Number Identification

| MODEL IDENTIFICATION | DSL DESIGNATION |
|---|-----------------|
| Model 16A2133-90*037 Alarm high, low, absolute or deviation Heat (reverse acting) Cool (direct acting) Input 1000 ohm 2 wire RTD, convertible to thermocouple, DC volts, DC amps | Standard |
| Model 16A2133-90*037-() -232: serial port for customer-supplied software -485: comm port for optional ProTrac [®] - or customer-supplied software | RS |
| Model 16A2153-90*037 Similar to Standard above except, 0-20 mA current control output | MAC |
| Model 16A2123-90*037 Similar to Standard above except, 15 VDC control output | VC |
| Model 16A2133-90*037-() -mA: Temperature retransmission, 4-20 mA -VDC: Temperature retransmission, 0 to 10 VDC | VR |

General Description

The DSL digital temperature control is a programmable and microprocessor based device that operates two relays for temperature control.

Features

The temperature sensor (RTD or thermocouple) sends a signal to the DSL to compare to a value preset by the user as a Set Point (SP). Set Points LEDs are **SP1** and **SP2** on the front panel.

- In heating mode (reverse acting) if the sensor signal is lower than the SP1 Set Point value, DSL energizes the SP1 relay and its isolated contacts close.
- In cooling mode (direct acting) if the sensor signal is higher than the SP2 Set Point value, DSL energizes SP2 relay and its isolated contacts close.
- Control outputs 1 and 2 can be configured from On-Off control to a manual or auto-tune PID control output. Refer to the Secure Menu section for programming details.
- DSL has a programmable alarm output. It can be programmed to act as a high-temperature alarm, a low-temperature alarm, or both. The alarm conditions can be programmed to reset automatically or require a manual reset. When the sensor signal exceeds an alarm set point, DSL goes into an alarm condition. In an Alarm Condition, both relays de-energize and the screen displays a flashing AAA. Refer to the Secure Menu section for programming details.

Installation

DSL is for indoor use only.

- 1 Unpack and inspect DSL for damage upon receipt. Shipping damage claims must be made through the freight carrier.
- 2 Install the DSL in a location that is not subject to excessive temperature, shock, or vibration. All DSL models are designed for mounting in an enclosed panel.
- 3 Select the desired position for the DSL controller on the panel. If more than one DSL is required, clearance allowances for the mounting collar access should be considered as shown here.

- 4 Prepare the panel by cutting and deburring the required 1/16th DIN opening.

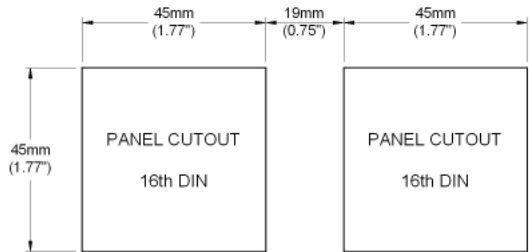

- 5 Remove the Retaining Collar. If necessary insert a flathead screwdriver under the collar on alternating sides while sliding the collar back.
- 6 From the front of the panel, slide the DSL controller through the cutout. The housing gasket should provide a seal between the housing flange and the panel.
- 7 From the rear side of the panel, slide the mounting collar over the housing with one hand. Use the other hand to hold the DSL housing from the front of the panel. Push the collar evenly against the panel until the spring loops are slightly compressed. The ratchets will hold the mounting collar and housing in place.

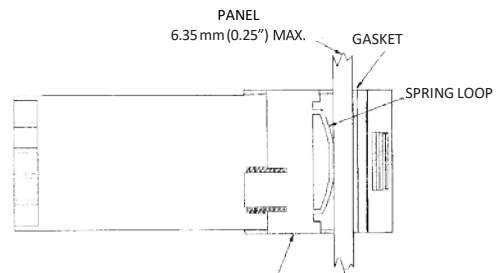

MOUNTING COLLAR (SHOWN IN POSITION) SLIDE COLLAR ONTO THE HOUSING BEFORE WIRING THE REAR TERMINALS

Wiring

This section provides wiring notes for Power Heating/Cooling relays and Overtemperature Protection.

Overtemperature Protection

Component failure (sensors, relays, temperature controller, etc.) in a temperature controlled process can result in damage to the product, heater over temperature, and the possibility of a fire.

To safeguard against these events, install over temperature protection. This will interrupt the heater power supply in the event of low solution level.

Process Technology heaters include a thermal device (Protector 1, 2, or 3) on the heater to monitor the heater's surface temperature. When wired properly, these devices cut the power to the heater in low solution level conditions. In addition to thermal protection, Process Technology requires the use of liquid level controls to monitor the solution level and shut off the heaters prior to an overtemperature condition occurring.

Ensure you read and adhere to all Over-temperature protector installation instructions and warnings.

WARNING

Overtemperature protection is necessary in any system where a fault condition could produce a fire or any other hazardous condition. Operation without thorough safety precautions can result in equipment failure, property damage and personal injury.

AVERTISSEMENT

La protection de surchauffe est nécessaire dans n'importe quel système où une condition fautive avec résultat d'une température haute pourrait produire un incendie ou autre condition dangereuse. L'opération sans les précautions complètes de sécurité pourrait mener à la défaillance de l'équipement, l'endommagement de la propriété, ou des

Overtemperature Protection Device with Low Level Cutoff Sample Wiring Diagram

(your wiring may differ)

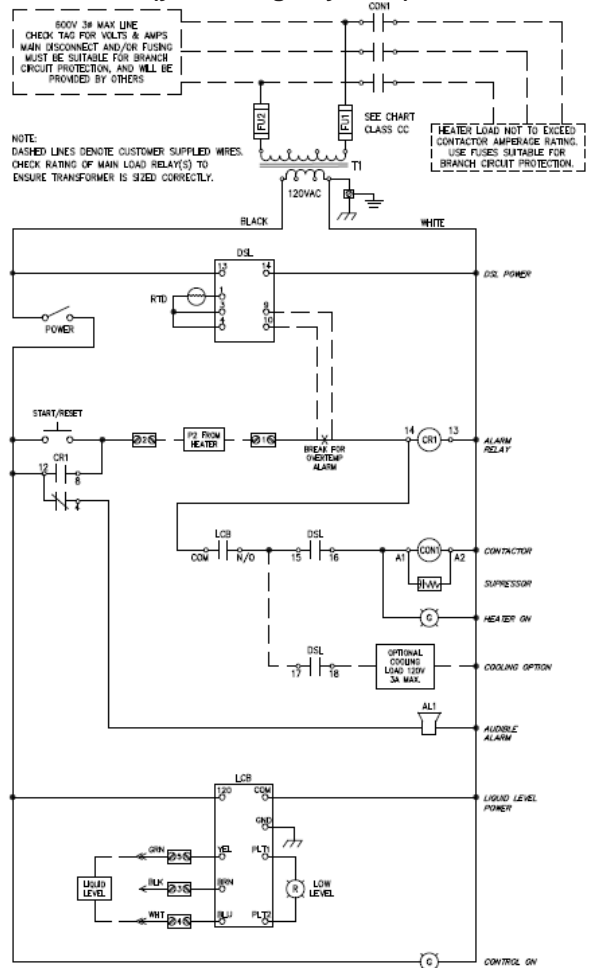

Power and Relay Wiring Procedure

Unit is intended for a single power source. To complete the wiring procedure, you will need these tools and materials:

1. Phillips head or straight-blade screwdriver.
2. Power supply wire, 18 awg minimum.
3. Relay connection wires (see state and local electrical requirements for proper 65°C wire gage)

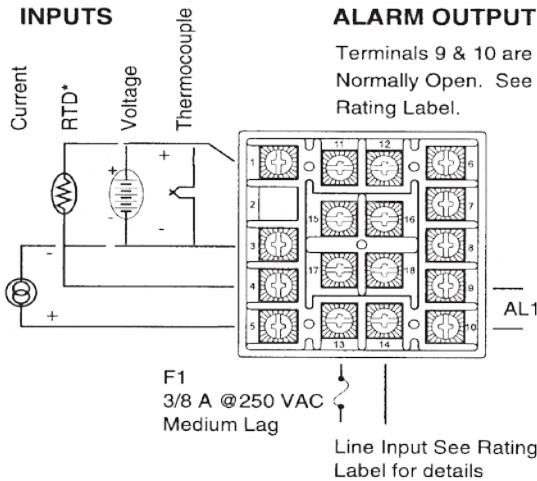

- For 2-wire 1000 ohm RTD or 2-wire 100 ohm RTD use terminals 1 & 3 and place a jumper between terminals 3 & 4.

Do not run thermocouple or other signal wiring in the same conduit as power leads. Use only the type of thermocouple or RTD probe for which the control has been programmed. Maintain separation between wiring of sensor, auxiliary in or out, and other wiring. See the "Secure Menu" for input selection.

For thermocouple input, always use extension leads of the same type designated for your thermocouple. For 2 wire RTD sensors, supply a jumper between terminals 3 & 4. For supply connections, use No. 16 AWG or larger wires rated for at least 75°C. Use copper conductors only. All line voltage output circuits must have a common disconnect and be connected to the same pole of the disconnect.

Input wiring for thermocouple, current, and RTD; and output wiring for current and 15 VDC is rated CLASS 2.

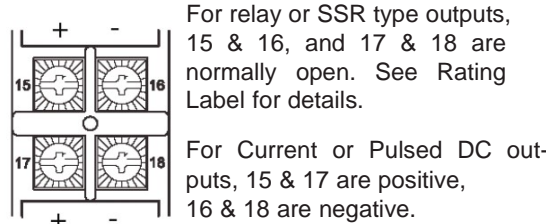

Referring to the illustrations above, locate and identify terminal locations for the power supply voltage, the set point relay, and the appropriate sensor. Connect wires into their designated terminals and tighten the retaining screw which will secure the wire into place.

Wiring for 4-20 mA Transmitter Inputs

Wire power and outputs as shown above. Two-wire transmitters wire as shown below. For three or four wire transmitters follow, the wiring instructions provided with your transmitter.

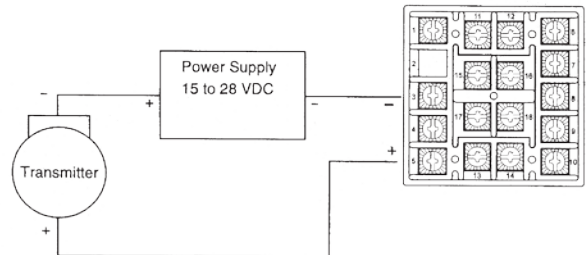

Wiring for Optional Inputs and Outputs

Wire power and outputs as shown on previous pages. All wiring shown below is Class 2. Shielded twisted pair is required for RS-485 option.

Do not run signal wiring in the same conduit or chase as the power wiring. Erratic operation or control damage will result.

Extending Wiring

The factory supplied 1000 ohm RTD sensor can be extended using standard electrical hookup wire (22 awg or larger). The effect of additional 22 awg sensor wire length on control calibration is approximately 1°F for every 65 feet.

Note: This does not apply to THERMOCOUPLES. You MUST use specific thermocouple wire when extending the sensor wire length. Use of incorrect extension wire can cause hazardous operating conditions.

| OPTION | 11 | 12 | 6 | 7 | 8 | |
|---|---------|----------|---------------|----|----|----|
| R E S T O R T A N C E | VDC | + | - | na | na | na |
| | mA | + | - | na | na | na |
| | ohms | CCW | Wiper | na | na | na |
| 4-STAGE | na | na | Signal Ground | A | B | |
| -485 | B | A | na | na | na | |
| -232 | Data In | Data Out | Signal Ground | na | na | |

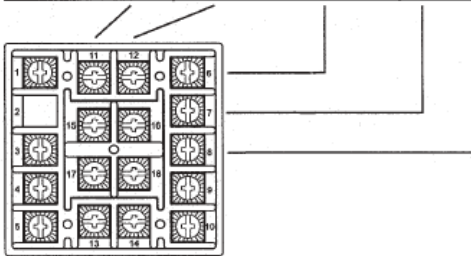

4-STAGE SET POINT TABLE

| | |
|--------------------------|------|
| A and B Open | 1SP1 |
| A to Signal Ground | 2SP1 |
| B to Signal Ground | 3SP1 |
| A and B to Signal Ground | 4SP1 |

Programming

Before operation, you must program Set Points and/or temperature limits.

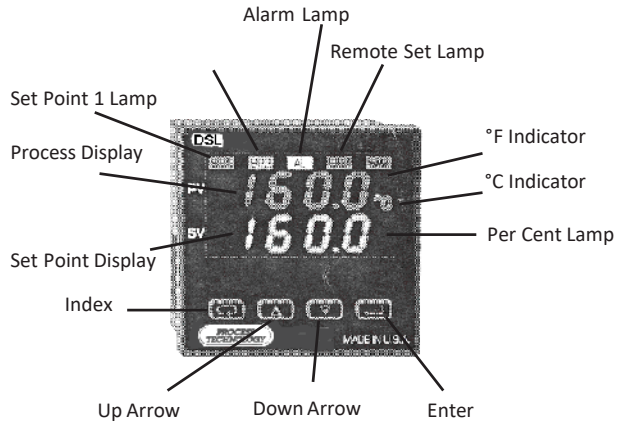

Keys are illuminated when pressed. Key functions are as follows:

INDEX: Pressing the INDEX key advances the display to the next menu item. May also be used with other keys as noted. For the primary menu (factory default), you will advance through the SP1, SP2 and AIHi settings.

UP ARROW: Increments (increases) a value, changes a menu item, or selects the item to ON. The maximum value obtainable is 9999, regardless of decimal point placement.

DOWN ARROW: Decrements (decreases) a value, changes a menu item, or selects the item to OFF. The minimum value obtainable is -1999, regardless of decimal point placement.

ENTER: Pressing ENTER stores (updates) the value or the item changed. If not pressed, the previously stored value or item will be retained. The display will flash once when ENTER is pressed.

UP ARROW & ENTER: Pressing these keys simultaneously brings up the secondary menu starting at the PEA, UAL, SP1d, etc. Pressing these keys for 5 seconds will bring up the secure menu.

Programming, Continued

INDEX & DOWN ARROW: Pressing these keys simultaneously will allow backing up one menu item, or if at the first menu item, they will cause the display to return to the primary menu. If an alarm condition has occurred, these keys may be used to reset the alarm. To reset an alarm, press and hold both keys for three seconds.

INDEX & ENTER: Pressing these keys simultaneously and holding them for 5 seconds allows recovery from the various error messages. The following menu items will be reset:

ALiH: Alarm inhibit

OPEn InP: Input error message

bAd InP: Input error message

CHEC CAL: Check calibration error

Correct the problems associated with the above conditions before using these reset keys. More than one error could be present. Caution is advised, since several items are reset at one time.

The Home Display

The home display is the normal display while the control is operating. If no errors or functions are active, the HOME display will indicate the Process Variable (the temperature, pressure, flow, RH, etc., that is being measured) on the top display and the Set Variable (Set Point 1) on the bottom.

If PctO (Secure Menu) is turned On, the lower display changes to show the active percentage of output as required to maintain SP1 and SP2. The value displayed is no longer the SV, but percent output. The SP2 output is indicated by the use of an overline on the letter \bar{o} .

Access to the SP1 or SP2 value is done by the INDEX key. If the control has both SP1 and SP2, the lower display will alternate between the SP1 percent output and the SP2 percent output.

Error messages are listed on the following two pages.

Notation Conventions for the Menus

Because of the number of features available in this control, information is included that may not apply to your specific control. All usable features are included in this book, but may not be used in your process. To increase clarity, the following conventions are used:

1. Certain features, menu items, and functions shown in this book may or may not appear on your control, depending on other menu Item selections. At various places in the menus there are notes identifying menu items that “control” or “direct” other menu items. If you are looking for a particular menu item and can’t find it, check the menu item that is its “control” for proper setting.
2. The “#” symbol is used in two ways. It is used inside a group of characters to indicate which set point function (SP1 or SP2) is being affected. It is also used before a group of characters of a menu item to indicate that there may be more than one selection or value for that menu item.
3. Features that apply only to Options will be printed in italics.

Menu Selections

Security Level Selection

Four levels of security are provided. Selecting a specific security level will inhibit casual access by operating personnel wishing to alter various programmed parameters. Accessing the security level menu will display the current security level. To change security levels, change the password value using the **UP & DOWN ARROW** keys and pressing the **ENTER** key. Refer to the password table (following) for the correct value to enter for the security level desired. The **SECr** menu item security level may be viewed or changed at any time regardless of the present security level. The factory setting is security level 2.

To access the security level and change it to, for example, **3**, press and hold for at least 4 seconds the **UP ARROW** and **ENTER** keys simultaneously. The **SECr** menu will appear indicating the current security level. Press the **UP ARROW** key until the upper display indicates **1011**. Press the **ENTER** key. The display will blink and will indicate the new security level, **3**, in the upper display.

Security Level Selection

The password values shown in the table cannot be altered, so retain a copy of these pages for future reference. This is the only reference made to password values in this instruction book.

| Security Level | | Displayed Value When Accessed | Password Value To Enter |
|--------------------------------|----------------------------------|-------------------------------|-------------------------|
| Menu | Status | | |
| Primary Secondary Secure | Locked Locked Locked | 1 | 1110 |
| Primary Secondary Secure | Unlocked Locked Locked | 1 | 1101 |
| Primary Secondary Secure | Unlocked Unlocked Locked | 3 | 1011 |
| Primary Secondary Secure | Unlocked Unlocked Unlocked | 4 | 111 |

Primary Menu

Press **INDEX** to advance to the next menu item. Press **UP ARROW** or **DOWN ARROW** to change the value in the display. Press **ENTER** to retain the value.

- #SP1** (optional 4-Stage Set Point) or
SP1 Set Point 1 Adjust, Control Point 1.
SP2 Set Point 2 Adjust, Control Point 2.
AIo Alarm Low: The Low Alarm point is usually set below the Set Point. Alarm Low will not appear unless selected at **AL1** setting in **Secure Menu**.
AIHi Alarm High: The High Alarm Point is usually set above the Set Point.

Secondary Menu

Hold **UP ARROW** & **ENTER**. Press **INDEX** to advance to the next menu item. Press **UP ARROW** or **DOWN ARROW** to change the value in the display. Press **ENTER** to retain the value.

PEA The Peak feature stores the highest input the control has measured since the last reset or Power On. At Power On, **PEA** is reset to the present input. To manually reset the value, **PEA** must be in the lower display. Press the **ENTER** key to reset.

PEA will be reset and display the present input value.

UAL The Valley feature stores the lowest input the Instrument has measured since the last reset or Power On. At Power On, **UAL** is reset to the present input. To manually reset the value, **UAL** must be in the lower display. Press the **ENTER** key. **UAL** will be reset and display the present input value

SP#d Set Point On-Off Differential (hysteresis). Select **1** to **9999** (direct acting), or **-1** to **-9999** (reverse acting). This value will be negative for reverse acting set points, and positive for direct acting outputs. Set the value for the amount of difference between the turn off point (set point) and the turn on point. The following drawing shows output behavior for reverse and direct action.

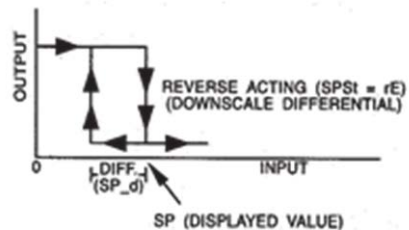
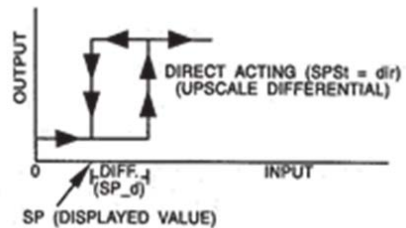

InPC Input Correction: Select $\pm 0-500$ °F, °C, or counts. This feature allows the input value to be changed to agree with an external reference or to compensate for sensor error.

Note: **InPC** is reset to zero when the input type is changed, or when decimal position is changed.

SECONDARY MENU OPTIONS

-VR Option

The analog retransmission option allows the Process Variable or the Set Variable to be sent as an analog signal to an external device. The signal may be either 0 to 10 VDC (Option **-VDC**) or 0 (or 4) to 20 mA (Option **-mA**). The output may be changed in the field from one to the other by the toggle switch located on the top printed circuit board. Wire the output as shown on page 5.

To set up the analog retransmission, first determine the scale range that the analog signal will represent. The maximum scale is 9999°F, 5530°C, or 9999 counts. In the Secondary Menu set **POL** for the scale value that will be represented by the low end of the analog signal (0 Volts or 0 mA). Set **POH** for the scale value that will be represented by the high end of the analog signal (10 Volts or 20 mA). If you require a suppressed scale or output, you may use the following equations to determine the proper settings for **POL** and **POH**.

K (Highest desired scale reading - Lowest desired scale reading) ÷ (Maximum desired analog signal - Minimum desired analog signal).

POH (Maximum possible analog output - Maximum desired analog signal X K) + Highest desired scale reading.

POL Lowest desired scale reading - (Minimum desired analog output X K).

Example

Span of 0-500°F with a 4-20mA output

$K = (500-0)/(20-4) = 31.25$

$POH = ((20-4) \times 31.25) + 500 = +500$

$POL = 0 - (4 \times 31.25) = -125$

Next, select whether you want the retransmission signal to follow the Process Variable or the Set Variable. Usually the Process Variable is sent to recorders or other data acquisition devices. Usually the Set Variable is sent to other controls to be used as an analog remote set point. If you want the analog retransmission signal to follow the PV, in the Secondary Menu set **POSr** to **InP**.

If you want the analog retransmission signal to follow the SV, set **POSr** to **Spt**. Operation is

automatic. No further programming steps are required.

4-Stage Control Option

The 4-stage set point option allows four different values to be used for **SP1** and all of the values associated with the **tunE** menu items. The control will switch to a given stage when an external contact or contacts are made or opened across the appropriate terminals at the rear of the control (when **SPSA**, Set Point Switch Action, is set for remote, **rE**), or when the stage is selected from the Secondary Menu, **SP** (when **SPSA** is set for **Int**). When the state of a contact changes (or the stage number is changed in the Secondary Menu), the values in use are stored and the previously stored values for the new stage are used.

Wire the input as shown on page 6.

Usually the control is configured for external switching of the stages. In this case, the operation is usually automatic, selected by the external switches driven by the machine logic. If it is necessary to program the stages in advance, you may select the stage to modify with the **SP** menu item. When **SP** is changed while the **SPSA** is set for **rE**, the selected stage is displayed for modification, but only used when the appropriate contact is made.

-RS Option, Serial Communication

The serial communications options allow the control to be written to and read from a remote computer or other similar digital device. Communication is allowed either through an RS-485 (Option **-485**) port, or an RS-232 (Option **-232**) port. Wire the communication lines as shown on Page 5, diag. 6.

Wiring for the RS-485 is run from control to control in a daisy chain fashion with a termination resistor (120 ohms) across the transmit and receive terminals of the last control in the chain.

A RS485/232 transceiver and PROTRAC software package are available for purchase if you do not have your own software.

Select the control address and communication baud rate with the **Addr** and **BAUD** menu items in the Secure Menu. THE BAUD RATE AND ADDRESS MENU ITEMS WILL TAKE EFFECT ON THE NEXT POWER UP OF THE CONTROL. BE SURE TO POWER CYCLE THE CONTROL BEFORE USING THE NEW BAUD RATE AND ADDRESS.

In operation, you have the option of preventing a write command from the host computer. To prevent the host from writing to the control, change the **LORe** menu item in the Secondary Menu to **LOC**. To allow the host to write commands to the control, set **LORe** to **rE**. (The host does have the ability to change the **LORe** state, but it is not automatic.)

If your system depends on constant reading or writing to and from the host, you may wish to set the No Activity Timer (**nAt**) to monitor the addressing of the control. When the **LORe** is set to **rE** and the **nAt** is set to any value other than Off, the control will expect to be addressed on a regular basis. If the control is not addressed in the time set by the value of **nAt**, then the control will display the error message **CHEC LORe**. To clear the message, set **LORe** to **LOC**.

4 stage set point option:

SP (4-Stage Set Point) Active Set Point Stage. Select **1SP1**, **2SP1**, **3SP1**, **4SP1**.

- 1SP1** Set Menu Items to display Stage 1 for view and change access. If **SPSA** is set for **Int**, **1SP1** is made active.
- 2SP1** Set Menu Items to display Stage 2 for view and change access. If **SPSA** is set for **Int**, **2SP1** is made active.
- 3SP1** Set Menu Items to display Stage 3 for view and change access. If **SPSA** is set for **Int**, **3SP1** is made active.
- 4SP1** Set Menu Items to display Stage 4 for view and change access. If **SPSA** is set for **Int**, **4SP1** is made active.

Remote set point option:

- rSPt** (Analog Remote Set Point) Remote Set Point: Select **On** or **OFF**.
OFF The control uses the value set for **SP1**.
On The control uses the value set by the analog remote set point signal as established by the Secure Menu items **rSCL** and
- rSCH** If the analog signal fails, the control will display the error message **CHEC/ LorE** and revert to the **SP1** local value.

-RS option:

- LORe** (Serial Communications) Local/Remote Status: Select **LOC** or **rE**.
LOC The host computer is advised not to send remote commands. Any write commands sent to the controls will be rejected.
rE The host computer is allowed to send write commands. If the control is not addressed within the time set in the **nAt** (No Activity Timer, see Secure Menu), the **CHEC LorE** error message will be displayed.
- rE** The host computer is allowed to send write commands. If the control is not addressed within the time set in the **nAt** (No Activity Timer, see Secure Menu), the **CHEC LorE** error message will be displayed.
- Addr** (Serial Communications) Control Address: Set from 1 to 3FF. This number (hexadecimal, base 16) must match the address number used by the host computer. Viewed only in this menu. To change this parameter, see **Addr** in the Secure Menu

Menu Selections, Continued

Secure Menu

Hold **UP ARROW** & **ENTER** for 5 Seconds. Press **INDEX** to advance to the next menu item. Press **UP ARROW** or **DOWN ARROW** to change the value in the display. Press **ENTER** to retain the value.

OUTPUTS ARE DISABLED (TURNED OFF) WHILE CONTROL IS IN SECURE MENU.

SECr Security Code: See the Security Level Selection and the Password Table on page 10 of this manual in order to enter the correct password.

Note: The menu items for **tunE** (below) are modified when 4 Stage Set Point is in use. When 4 Stage Set Point is active, the menu items are preceded with the stage number selected in **SP** above. The stage number is noted here with the **#** sign. When the 4 Stage Set Point option is active, each stage has its own set of **tunE** parameters.

#tun (4-Stage Set Point) or
tunE Tuning Choice: Select **SELF**, **Pid**, **SLO**, **nor**, or **FASt**.

SELF The Controller will evaluate the Process and select the PID values to maintain good control. Active for SP1 only.

LErn Select **YES** or **no**

YES Start Learning the Process. After the process has been learned, the menu item will revert to **no**.

no Learning will stay in present mode.

dFAC Damping factor, Select **OFF**, **1** to **7**. Sets the ratio of Rate to Reset for the **SELF tunE** mode. **7** = most Rate. Factory set to **3**. For a fast response process, the value should be lowered (less Rate). For a slower process, the value should be increased (more Rate).

Pid Manually adjust the PID values. PID control consists of three basic parameters: Proportional Band (Gain), Reset Time (Integral), and Rate Time (Derivative).

#Pb1 (4-Stage Set Point) or

Pb1 Proportional Band (Bandwidth). Select **1** to **9999**°F, °C, or counts.

Pb2 Proportional Band (Bandwidth). Select **1** to **9999**°F, °C, or counts. Appears only if control is equipped with second set point and **Out2** is NOT selected as **ONOF**.

#rES (4-Stage Set Point) or
rES Automatic Reset Time. Select **OFF**, **0.1** to **99.9** minutes. Select **OFF** to switch to **OFS**.

#OFS (4-Stage Set Point) or
OFS Manual Offset Correction. Select **OFF**, **0.1** to **99.9**%. Select **OFF** to switch to **rES**.

#rtE (4-Stage Set Point) or
rtE Rate Time. Select **OFF**, **0.01** to **99.99** minutes, derivative.

SLO PID values are preset for a slow response process.

nor PID values are preset for a normal response process.

FASt PID values are preset for a fast response process.

Pid2 Linkage of PID parameters between SP1 and SP2: Select **On** or **OFF**.

On Applies SP1 **rEs**, **rtE**, **Fbnd**, and **FrE** terms to SP2 for heat/cool applications.

OFF SP2 functions without **rEs**, **rtE**, **Fbnd** and **FrE**.

Menu Selections, Continued

Secure Menu, Continued

- ArUP** Anti- Reset Windup Feature: Select **On** or **OFF**.
- On** When ArUP is **On** the accumulated Reset Offset value will be cleared to 0% when the process input is not within the Proportional Band.
- OFF** When ArUP is **OFF**, the accumulated Reset Offset Value is retained in memory when the process input is not within the Proportional Band.
- ArtE** Approach Rate Time: Select **OFF**, **0.01** to **99.99** minutes. The function defines the amount of Rate applied when the input is outside of the Proportional Band. The **ArtE** time and the **rtE** time are independent and have no effect on each other. To increase damping effect and reduce overshoot, set the approach rate time for a value greater than the natural rise time of the process (natural rise time = process value time to set point).
- Fint** Fuzzy Logic Intensity: Select 0 to 100%. 0% is OFF (disables Fuzzy Logic). The function defines the amount of impact Fuzzy Logic will have on the output.
- Fbnd** Fuzzy Logic Error Band: Select 0 to 4000 °F, °C, or counts. Sets the bandwidth of the Fuzzy Logic. Set Fbnd equal to PID proportional band (Pb1) for best results.
- FrtE** Fuzzy Logic Rate of Change: Select 0.00 to 99.99 counts/second. For best initial setting, find the degrees/second change of process value near set point with output at 100%. Multiply this value by 3. Set **FrtE** to this calculated value.
- PctO** Percent Output Feature: Select **On** or **OFF**.
- On** When selected **On**, the HOME lower display will indicate the output of the controller in percent. An “o” will appear in the right hand side of the lower display to indicate percent output for SP1. An “o” will appear on the right hand corner of the lower display to represent percent output for SP2, if the control is so

- equipped. The display will alternate between these values.
- OFF** Percent Output display is disabled.
- InP** Input Type: Select one of the following. Refer to the Input wiring section for the proper wiring.
- J-IC** Type “J” Thermocouple, Iron/Constantan (NIST)
- CA** Type “K” Thermocouple Chromel/Alumel
- E-** Type “E” Thermocouple Chromel/Constantan
- t-** Type “T” Thermocouple Copper/Constantan
- L-** Type “L” Thermocouple Iron/Constantan (DIN)
- n-** Type “N” Thermocouple Nicrosil/Nisil
- r-13** Type “R” Thermocouple Pt 13%Rh/Pt
- S-10** Type “S” Thermocouple Pt 10%Rh/Pt
- b-** Type “B” Thermocouple Pt 6%Rh/Pt 30%Rh
- C-** Type “C” Thermocouple W 5%Re/W 26%Re
- P392** 100 ohm Platinum (NIST 0.00392 W/W/°C) RTD
- n120** 120 ohm Nickel RTD
- P385** 100 ohm Platinum (DIN 0.00385 W/W/°C) RTD
- 1P38** 1000 ohm Platinum (DIN 0.00385 W/W/°C) RTD
- Curr** DC Current Input 0.0 to 20.0 or 4.0 to 20.0 mA
- VoLt** DC Voltage Input 0.0 to 5.0 or 1.0 to 5.0 volts
- diFF** DC Voltage Input -10 to +10 mV
- Reserved
- OSUP** Zero Suppression: Select **On** or **OFF**. Only with Current and Voltage input types.
- OFF** The input range will start at 0 (zero) Input.
- On** The input range will start at 4.00 mA or 1.00 V.

Menu Selections, Continued

Secure Menu, Continued

| | | |
|--------------|--|--|
| Unit | F, C or nonE. | |
| F | °F descriptor is On and temperature inputs will be displayed in actual degrees Fahrenheit. | |
| C | °C descriptor is On and temperature inputs will be displayed in actual degrees Celsius. | |
| nonE | °F and °C descriptors will be Off. This is only available with Current and Voltage Inputs. | |
| dPt | Decimal Point Positioning: Select 0, 0.0 , 0.00 , 0.000 , or .0000 . On temperature type inputs, this will only effect the Process Value, SP1, SP2, ALLo, ALHi, and InPC. For Current and Voltage Inputs, all Menu Items related to the Input will be affected. | |
| 0 | No decimal point is selected. This is available for all Input Types. | |
| 0.0 | One decimal place is available for Type J, K, E, T, L, RTDs, Current and Voltage Inputs. | |
| 0.00 | Two decimal places is only available for Current and Voltage Inputs. | |
| 0.000 | Three decimal places is only available for Current and Voltage inputs. | |
| .0000 | Four decimal places is only available for Current and Voltage inputs. | |
| InPt | Input Fault Timer: Select OFF , 0.1 to 540.0 minutes. Whenever an Input is out of range (UFL or OFL displayed), shorted, or open the timer will start. When the time has elapsed, the controller will revert to the output condition selected by InPb below. If OFF is selected, the Input Fault Timer will not be recognized (time = infinite). If resolution is selected, this should be increased to 4. If this value is set too high, controllability will suffer. | |
| InPb | Input Fail Action: Select FAIL , AVE or PrE . When the INput is out of range (UFL or OFL displayed) and the Input timer (InPt) time has elapsed, the controller will revert to the selected condition. | |
| FAIL | Outputs are disabled (go to 0% output). | |
| AVE | The outputs will hold the last known average percentage of output. | |
| PrE | The outputs will maintain a preprogrammed percentage of output as specified in PrE1 and PrE2 . | |
| PrE1 | Preset output for Set Point 1. Select 0 to 100%. | |
| PrE2 | Preset output for Set Point 2. Select 0 to 100%. | |
| SEnC | Sensor Rate of Change: Select OFF , 1 to 4000 °F, °C, or counts per 1 second period. This value is usually set to be slightly greater than the fastest process response expected during a 1 second period, but measured for at least 2 seconds. If the process is faster than this setting, the SEnC bAd error message will appear. The outputs will then be turned off. This function can be used to detect a runaway condition, or speed up detection of an open thermocouple. Use the INDEX & ENTER keys to reset. | |
| Filt | Digital Filter: Select OFF , 1 to 99 . In some cases the time constant of the sensor, or noise, could cause the display to jump enough to be unreadable. A setting of 2 is usually sufficient to provide enough filtering for most cases (2 represents approximately a 1 second time constant). When the 0.1 degree resolution is selected, this should be increased to 4 . If this value is set too high, controllability will suffer. | |
| SCAL | Scale Low: Select 100 to 9999 counts below SCAH . The total span between SCAL and SCAH must be within 11998 counts. Maximum setting range is -1999 to +9999 counts. For Current and Voltage inputs, this will set the low range end. Viewable (cannot be changed) only for Thermocouple and RTD ranges. | |
| SCAH | Scale High: Select 100 to 9999 counts above SCAL . The total span between SCAL and SCAH must be within 11998 counts. Maximum setting range is -1999 to +9999 counts. For Current and Voltage inputs, this will set the high range end. Viewable (cannot be changed) only for Thermocouple and RTD ranges. | |

Menu Selections, Continued

Secure Menu, Continued

- SPL** Set Point Low: Select from the lowest input range value to SPH value. This will set the minimum SP1 or SP2 value that can be entered. The value for SP1 or SP2 will not stop moving when this value is reached.
- SPH** Set Point High: Select from the highest input range value to SPL value. This will set the maximum SP1 or SP2 value that can be entered. The value for SP1 or SP2 will not stop moving when this value is reached.
- SP10** Set Point 1 Output Select: Select **OutA** or **Outb**.
- OutA** Set Point 1 is routed through Output A, Set Point 2 (if equipped) is routed through Output B.
- Outb** Set Point 1 is routed through Output B, Set Point 2 (if equipped) is routed through Output A.
- Out1** Output selection: Select **OnOf**, **1tP**, **1PuL**, or **ProP**.
- ONOF** A setting of **ONOF** allows the control to operate as a simple on/off mode. This setting forces the control to turn off at set point, and on at the set point plus the differential (**SP_d**). When selected, the **Out1/OnOF** menu item is followed by **####/SP1d**, and the **tunE**, **Pb**, **rES**, **OFS**, **rtE**, and **ArUP** selections in the Secondary menu and the **S1OL** and **S1OH** selections in the Secure menu are suppressed.
- ##tP** Time Proportioning Cycle Time. Select **1tP** to **80tP**.
- 1tP** A setting of **1tP** is recommended for solid state outputs (SSR or 15VDC).
- 2tP to 80tP** Time Proportioning Control is adjustable in 1 second steps. Recommended for mechanical outputs (relays, solenoids, etc.). For best contact life, a time should be selected as long as possible without causing

the process to wander.

#PuL Pulsed Time Proportioning Output: Select **1PuL** to **7PuL**. **1PuL** = Linear and **7PuL** = most non-linear. Changes output linearity for use in cooling applications or for an extremely fast response processes. At the center of the proportional band, a pulse value of 1 provides an output of one second on and one second off (50% output). A pulse value of 2 provides an output of one second on and two seconds off (33% output). Output at center of band equals one second on, 2 (pulse value-1) seconds off.

ProP For Current (Code 5) outputs only.

S1St Set Point 1 State: Select **dir** or **rE**.

dir Direct Action. As the input increases, the output will increase. Most commonly used in cooling processes.

rE Reverse Action. As the input increases, the output will decrease. Most commonly used in heating processes.

If **Out1** is set for **##tP**, **#PUL**, or **ProP**, then **S1OL** and **S1OH** (following) appear. If **Out1** is set for **ONOF**, then skip to **S1rE**.

S1OL Set Point Output Low Limit: Select **0** to **100%** but not greater than **S1OH**. This item limits the lowest output value. This is useful for adding a bias to the process when needed. Factory set to **0** for output codes 1,2, and 3. Factory set to **20** for output code 5 (20% output equals 4 mA output).

Menu Selections, Continued

Secure Menu, Continued

S1OH Set Point 1 Output High Limit: Select **0** to **100%** but not less than **S1OL** for output codes 1, 2, or 3. Select **0** to **102%** but not less than **S1OL** for output code 5. This item allows setting the maximum output limit. This is useful with processes that are over powered. Adjustment to 102% allows setting current output to force a full ON condition for output devices which do not have bias adjustments. Factory set to 100 for all output codes. If **Out1** is set for **##tP**, **#PUL**, or **ProP**, then skip to **S1LP** below.

S1rE Set Point 1 Reset. Select **OnOF** or **Hold**.

OnOF Control will automatically reset when process passes back through **SP1d**.

HoLd Manual Reset. Reset (acknowledge) by simultaneously pressing the **INDEX & DOWN ARROW** keys for 5 seconds.

S1Pi Set Point 1 Power Interrupt. Select **On** or **OFF**.

On Alarm Power Interrupt is **On**. Control will automatically reset on power-up if no alarm condition exists.

OFF Alarm Power Interrupt is **OFF**. Control will power-up in alarm condition regardless of condition of process.

S1iH Set Point 1 Inhibit: Select **On** or **OFF**.

On Alarm Inhibit is **On**. Alarm action is suspended until the process value first enters a non-alarm condition.

OFF Alarm Inhibit is **OFF**.

S1LP Set Point Lamp: Select **O on** or **OoFF**.

O on Lamp ON when Output is ON.

OoFF Lamp OFF when Output is ON.

If your control is not equipped with Set Point 2, then proceed to the alarm section (page ##).

S2t Set Point 2 type: Select **Abs** or **dE**.

AbS Absolute **SP2**. **SP2** is independent of **SP1**, and may be set anywhere between the limits of **SPL** and **SPH**.

dE Deviation **SP2**. **SP2** is set as a deviation from **SP1**, and allows **SP2** to retain its relationship with **SP1** when **SP1** is changed (tracking **SP2**).

Out2 Output selection: Select **OnOf**, **2tP**, **2PuL**, or **ProP**.

ONOF A setting of **ONOF** allows the control to operate as a simple on/off mode. This setting forces the control to turn off at set point, and on at the set point plus the differential (**SP2d**). When selected, the **Out2/OnOF** menu item is followed by **####/SP2d**, and the **Pb2** selection in the Secondary menu and the **S2OL** and **S2OH** selections in the Secure menu are suppressed.

SP2d Set Point On-Off Differential (hysteresis). Select **1** to **9999** (direct acting), or **-1** to **-9999** (reverse acting). This value will be negative for reverse acting set points, and positive for direct acting outputs. Set the value for the amount of difference between the turn off point (set point) and the turn on point. Diagram 8 on page 12 shows output behavior for reverse and direct action.

Menu Selections, Continued

Secure Menu, Continued

- ##tP** Time Proportioning Cycle Time. Select **1tP** to **80tP**.
- 1tP** A setting of **1tP** is recommended for solid state outputs (15VDC).
- 2tP to 80tP** Time Proportioning Control is adjustable in 1 second steps. Recommended for mechanical outputs (relays, solenoids, etc.). For best contact life, a time should be selected as long as possible without causing the process to wander.
- #PuL** Pulsed Time Proportioning Output: Select **1PuL** to **7PuL**.
- 1PuL** = Linear and **7PuL** = most nonlinear. Changes output linearity for use in cooling applications or for extremely fast response processes. At the center of the proportional band, a pulse value of 1 provides an output of one second on and one second off (50% output). A pulse value of 2 provides an output of one second on and two seconds off (33% output). Output at center of band equals one second on, 2 (pulse value-1) seconds off.
- ProP** For Current (Code 5) outputs only.
- S2St** Set Point 2 State: Select **dir** or **rE**.
- dir** Direct Action. As the input increases, the output will increase. Most commonly used in cooling processes.
- rE** Reverse Action. As the input increases, the output will decrease. Most commonly used in heating processes.

If **Out2** is set for **##tP**, **#PUL**, or **ProP**, then **S2OL** and **S2OH** (following) appear. If **Out2** is set for **ONOF**, then skip to **S2rE**.

- S2OL** Set Point Output Low Limit: Select **0** to **100%** but not greater than **S2OH**. This item limits the lowest output value. This is useful for adding a bias to the process when needed. Factory set to **0** for output codes 1,2, and 3. Factory set to **20** for output code 5 (20% output equals 4 mA output).
- S2OH** Set Point 1 Output High Limit: Select **0** to **100%** but not less than **S2OL** for output codes 1, 2, or 3. Select **0** to **102%** but not less than **S2OL** for output code 5. This item allows setting the maximum output limit. This is useful with processes that are over powered. Adjustment to 102% allows setting current output to force a full ON condition for output devices which do not have bias adjustments. Factory set to **100** for all output codes.
- S2rE** Set Point 2 Reset. Select **OnOF** or **Hold**.
- OnOF** Control will automatically reset when process passes back through **SP2d**.
- HoLd** Manual Reset. Reset (acknowledge) by simultaneously pressing the **INDEX & DOWN ARROW** keys for 5 seconds.
- S2Pi** Set Point 2 Power Interrupt. Select **On** or **OFF**.
- On** Alarm Power Interrupt is **On**. Control will automatically reset on power-up if no alarm condition exists.
- OFF** Alarm Power Interrupt is **OFF**. Control will power-up in alarm condition regardless of condition of process.
- S2iH** Set Point 2 Inhibit: Select **On** or **OFF**.
- On** Alarm Inhibit is **On**. Alarm action is suspended until the process value first enters a non-alarm condition.
- OFF** Alarm Inhibit is **OFF**.
- S2LP** Set Point 2 Lamp: Select **O on** or **OoFF**.
- O on** Lamp ON when Output is ON.
- OoFF** Lamp OFF when Output is ON.

Menu Selections, Continued

Secure Menu, Continued

ALARM TYPE AND ACTION (if present)



CAUTION

In any critical application where failure could cause expensive product loss or endanger personal safety, a redundant limit controller is required.



ATTENTION

Attention: Dans n'importe quelle application critique où un échec pourrait mener à une perte onéreuse ou mettre en danger le personnel, il faut un contrôleur de limite redondant.

When setting an alarm value for an absolute alarm (**A#t = AbS**), simply set the value at which the alarm is to occur.

When setting the alarm value for a deviation alarm (**A#t = dE**), set the difference in value from the Set Point (SP) desired. For example, if a low alarm is required to be 5 degrees below the SP, then set **A#Lo** to -5. If a high alarm is required 20 degrees above the SP, then set **A#Hi** to +20. If SP is changed, the alarm will hold the same relationship as originally set.

The diagram below shows the action and reset functions for both absolute and deviation alarms.

ABSOLUTE ALARMS

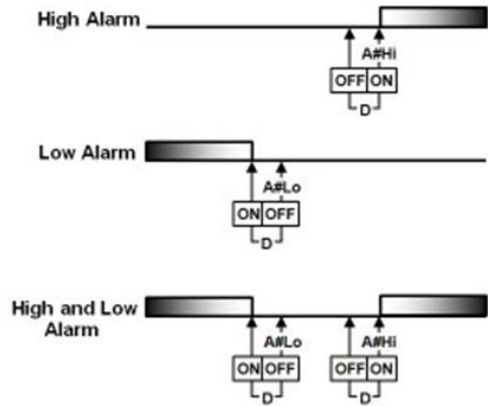

DEVIATION ALARMS

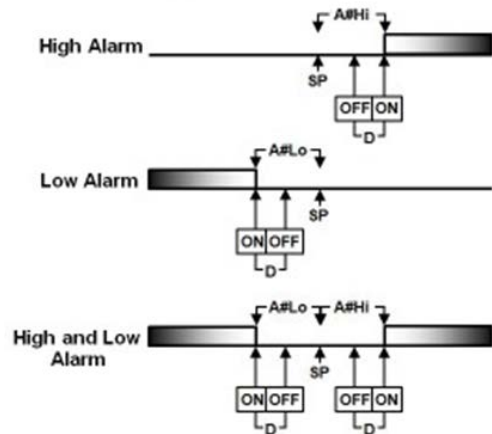

When Alarm Power Interrupt, **A#Pi**, is programmed **ON** and Alarm Reset, **A#rE**, is programmed for **Hold**, the alarm will automatically reset upon a power failure and subsequent restoration if no alarm condition is present.

Menu Selections, Continued

Secure Menu, Continued

If Alarm Inhibit, **A#IH**, is selected **ON**, an alarm condition is suspended upon power up until the process value passes through the alarm set point once. Alarm inhibit can be restored as if a power up took place by pressing both the **INDEX** and **ENTER** keys for 5 seconds.

The following menu items apply only to the alarm.

AL1 Alarm 1 function: Select **OFF**, **Lo**, **Hi**, **HiLo**, or **Evnt**.

OFF Alarm 1 is disabled. No Alarm 1 menu items appear in the Secondary or Secure menus.

Lo Low Alarm Only. **A1Lo** appears in the Secondary Menu.

Hi High Alarm Only. **A1Hi** appears in the Secondary Menu.

HiLo High and Low Alarms. Both **A1Lo** and **A1Hi** appear in the Secondary Menu, and share the same Alarm 1 Relay output.

Evnt Alarm 1 is controlled by an external event.

If **AL1** is set to **OFF** and the control is not equipped with options, the Secure Menu ends. If **AL1** is set to **OFF** and the control is equipped with options, proceed to **SPSA**, **Addr**, or **rSCL** below. If **AL1** is set to **Evnt**, go to **A1St**.



WARNING

Resetting a high alarm inhibit will not cause an alarm to occur if the Process Value does not first drop below the high alarm setting. Do not use the Alarm Inhibit feature if a hazard is created by this action. Be sure to test all combinations of high and low alarm inhibit actions before placing control into operation.



AVERTISSEMENT

La réinitialisation d'une inhibition d'alarme haute ne causera pas la reproduction d'une alarme si en premier la température du processus ne descend pas en dessous du réglage de l'alarme haute. N'utilisez pas l'inhibition d'alarme si un risque est créé par cet acte. Testez toutes les combinaisons d'inhibition d'alarme haute et basse avant de placer le contrôle en service.

A1t Alarm 1 Type: Select **AbS** or **dE**

AbS Absolute Alarm that may be set anywhere within the values of **SCAL** and **SCAH** and is independent of **SP1**.

dE Deviation Alarm that may be set as an offset from **SP1**. As **SP1** is changed the Alarm Point will track with **SP1**. A deviation alarm will also track any active ramp or soak set point.

A1rE Alarm 1 Reset: Select **OnOF** or **Hold**.

OnOF Automatic Reset.

Hold Manual Reset. Reset (acknowledge) by simultaneously pressing the **INDEX** & **DOWN ARROW** keys for 5 seconds.

Menu Selections, Continued

Secure Menu, Continued

- A1Pi** Alarm 1 Power Interrupt: Select **On** or **OFF**.
On Alarm Power Interrupt is **On**.
OFF Alarm Power Interrupt is **OFF**.
- A1iH** Alarm 1 Inhibit: Select **On** or **OFF**.
On Alarm Inhibit is **On**. Alarm action is suspended until the process value first enters a non-alarm condition.
OFF Alarm Inhibit is **OFF**.
- A1St** Alarm 1 Output State: Select **CLOS** or **OPEN**.
CLOS Closes Contacts at Alarm Set Point.
OPEN Opens Contacts at Alarm Set Point.
- A1LP** Alarm 1 Lamp: Select **O on** or **OoFF**.
O on Alarm Lamp is ON when alarm contact is closed.
OoFF Alarm Lamp is OFF when alarm contact is closed.
- A1Lb** Alarm 1 Loop break. Select **On** or **OFF**.
On Loop Break Condition will cause an Alarm Condition.
OFF Loop Break will not affect the Alarm Condition.
- LPbr** Loop Break Protection: Select **OFF**, **1** to **9999** seconds. If, during operation, the output is minimum (0%) or maximum (100%), and the input moves less than 5°F (3°C) or 5 counts over the time set for **LPbr**, the **LOOP bAd** message will appear. This condition can also be routed to an Alarm Condition if alarms are present and turned On (see **ALbr** in the secure menu). The loop break error can be reset by pressing the **ENTER** key when at the **LPbr** menu item. The **INDEX & ENTER** keys may also be used.
- SPSA** (4-Stage Set Point) Switch Action: Select **rE** or **Int**.
- rE** Set Point Stage selected by external contact closures.
- Int** Set Point Stage selected by internal menu selection. See **SP** menu item in Secondary Menu.

- Addr** (Serial Communications) Control Address: Set from **1** to **3FF**. This number (hexadecimal, base 16) must match the address number used by the host computer.
- bAUD** (Serial Communications) Communication Baud Rate: Select **300**, **1200**, **2400**, **4800**, **9600**, or **19200**. This number must match the baud rate used by the host computer.
- nAt** (Serial Communications) No Activity Timer: Set from **OFF** or **1** to **99** minutes.
1 - 99 Maximum time between host computer accesses. If timer counts to **0**, **CHEC/LorE** will be displayed.
OFF No Activity Timer function is disabled.
- rSCL** (Analog Remote Set Point) Remote Scale Low: Select **100** to **9999** counts below **rSCH**. The total span between **rSCL** and **rSCH** must be within 11998 counts. Maximum setting range is -1999 to +9999 counts.
- rSCH** (Analog Remote Set Point) Remote Scale High: Select **100** to **9999** counts above **rSCL**. The total span between **rSCL** and **rSCH** must be within 11998 counts. Maximum setting range is -1999 to +9999 counts.

PID Self-tune Function

Self Tune[®] allows automatic selection of the necessary parameters to achieve best control operation from your DSL Series control. If you are using the control output as a simple on-off function (**Out1** set for **OnOF**), none of the following will apply.

THEORY OF OPERATION

The Self Tune function calculates the **Pb1**, **rES**, and **rte** parameters under the **PID tunE** selection, and the **Fbnd** and **Frte** parameters, as shown in the Secure Menu. These values are determined by measuring the response of the process connected to the control. When Self Tune is started, the control temporarily acts as an on-off control. While in this mode, the control measures the overshoot and undershoot of the process, and the period of the process (the time from peak value to the next peak value). These measurements are collected over three periods of overshoot and undershoot. The data collected over this time is then compared and calculated into final PID and Fuzzy Logic values. The effect of Fuzzy Logic on the process is still controlled by the **Fint** (fuzzy intensity) setting. If **Fint** is 0, the **Fbnd** and **Frte** will be calculated, but will have no effect. The calculations for the PID values are the same as used in the standard Ziegler - Nichols equations that have been recognized as standard for decades. The only modification to the application of the Ziegler - Nichols equations is controlled by the **dfAC** menu item. This menu item controls the amount of rate (derivative) that is applied. A **dfAC** setting of **3** (factory default) or less allows for less damping. A **dfAC** setting of **4** allows for critical damping as set forth in Ziegler - Nichols. A **dfAC** setting of **5** or more allows over damping of the process.

Fuzzy Logic

The term "Fuzzy Logic" as used in this control describes a set of control algorithms which alter the output variables. They can be said to be a "smart" data manipulator. When properly applied, fuzzy logic can increase the heat-up response by virtue of the fuzzy band width (**Fbnd**), and improve system recovery after an upset by virtue of the fuzzy rate of change (**Frte**). This is particularly useful in high energy electric heating or anywhere that rapid process variables are present.

Since Fuzzy Logic modifies these output variables, we can increase or decrease this effect through adjustment of the fuzzy logic intensity (**Fint**). Review the setting information found on page 17 of this manual.

Program Setup and Operation

In the secondary menu, set **tunE** to **SELF**. Skip **LErn** and check to make sure that **dfAC** is set to the desired value. Back up to **LErn** and set to **YES**. The control will begin the Self Tune function. While the Self Tune function is active, the right hand decimal point on the lower display will blink. When Self Tune is complete, the blinking will stop. After Self Tune is complete, the **tunE** setting automatically switches to **PID**. This allows examination and/or modification of the values calculated. We recommend that you do not change the calculated values unless you have a firm understanding of the parameters involved and their function. For more information on PID tuning, please contact Process Technology Technical Sales personnel.

Diagnostic Error Messages

| DISPLAY | MEANING | SP OUTPUTS | ACTION REQUIRED |
|---|---|---|---|
| No display lighted | Display is blank. Instrument is not getting power or the supply voltage is too low. | Set point outputs inactive. Alarm Inactive. | Check that the power supply is on, or that the external fuses are good. |
| FAIL tEST | This message will appear upon power up if the internal diagnostics detect a failure. This message may occur during operation if a failure is detected. Displays flash. | Set point outputs inactive. Alarm inactive. | The display alternates between FAIL tEST and one of the following messages: FAct dFLt : Memory may be corrupted. Press the ENTER key and the DOWN ARROW key to start the factory default procedure. Recheck controller programming. rEt FAct : Unrecoverable error, return to factory for service. |
| CHEC SP1, CHEC SP2, CHEC 1SP, ..., CHEC16SP, | This message will appear upon power up if SP1, SP2, #SP1, or 33SP is set outside of the SPL or SPH values. | Set point outputs inactive. Alarm active. | Correct the SP1, etc. or adjust the SPL or SPH values by programming new values. |
| CHEC SPL or CHEC SPH | This message will appear at power up if SPL or SPH values are programmed outside the input range ends. | Set point outputs inactive. Alarm inactive. | Correct the SPL or SPH values by programming new values. |
| CHEC rSpt | This message will appear if the analog remote set point signal is out of range. | Set point outputs active. Alarm inactive. | The control will revert to SP1 . Correction of the analog signal allows the control to return to the remote. |
| CHEC LorE | This message will appear if the Serial Communications has timed out. | Set point outputs active. Alarm inactive. | Restore the communications line and switch the LorE to LOC. |
| UFL or OFL | Underflow or Overflow: Process value has exceeded input range ends. | Set point outputs active. Alarm active. | Input signals may normally go above or below range ends. If not, check input and correct. |
| bAd InP OPEn InP | UFL or OFL will sequence to display one of these messages if the InPt is set for a time value. For RTD inputs RTD is open or shorted. For THERMOCOUPLE inputs thermocouple is open. | Set point outputs inactive. Alarm active. | To reset, use the INDEX & ENTER keys. When InPt (Input fault timer) has been set for a time, the outputs will be turned off after the set time. Setting the time to OFF causes the outputs to remain active, however UFL or OFL will still be displayed. Correct or replace sensor. To reset use the INDEX & ENTER keys. |

Diagnostic Error Messages

| DISPLAY | MEANING | SP OUTPUTS | ACTION REQUIRED |
|-----------------|--|---|--|
| LOOP bAd | The sensor may be defective, heater fuse open, heater open, or the final power output device is bad. | Set point outputs inactive. Alarm active. | Correct or replace sensor, or any element in the control loop that may have failed. Correct the problem, and reset the control by pressing the INDEX and ENTER keys, or index to LPbr and press ENTER . |
| SEnC bAd | Sensor Rate of Change exceeded the programmed limits set for SEnC. | Set point outputs inactive. Alarm active. | Check for the cause of the error. The value setting may be too slow for the process, or the sensor is intermittent. Correct the problem and press INDEX and ENTER to reset. |
| CHEC CAL | The check calibration appears as an alternating message if the instrument calibration nears tolerance edges. | Set point outputs active. Alarm active. | Remove the instrument for service and/or recalibration. To reset use the INDEX & ENTER keys. |
| | The check calibration appears as a flashing message if the instrument calibration exceeds specification. | Set point outputs inactive. Alarm active. | Remove the instrument for service and/or recalibration. To reset use the INDEX & ENTER keys. |