

# SHX-Series

## Inline Chemical Heater

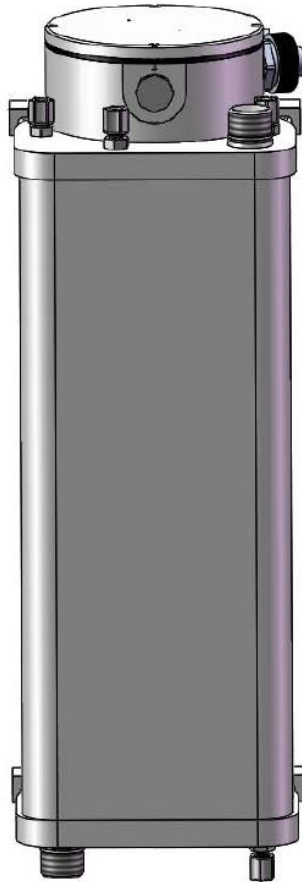

## Instruction Manual

Please supply your inline heater model and serial number when ordering spare parts or when requesting technical assistance.



[www.processtechnology.com](http://www.processtechnology.com)





7010 Lindsay Dr., Mentor, OH 44060 Phone: 440-974-1300 Fax: 440-974-9561 USA/CN: 800-621-1998

# **Table Of Contents**

<b>INTRODUCTION .....</b>	<b>2</b>
PERFORMANCE DATA .....	4
<b>HEATER SPECIFICATIONS .....</b>	<b>5</b>
<b>FACILITY REQUIREMENTS .....</b>	<b>6</b>
SPACE-REQUIREMENTS.....	6
LOCATION.....	6
MOUNTING.....	6
PLUMBING-REQUIREMENTS .....	6
PURGE GAS REQUIREMENTS .....	7
ELECTRICAL-REQUIREMENTS.....	8
<b>INSTALLATION: .....</b>	<b>9</b>
UNCRATING AND INSPECTION.....	9
MOUNTING HEATER.....	9
PROCESS-FLUID-CONNECTIONS .....	10
PURGE GAS CONNECTIONS .....	11
ELECTRICAL CONNECTIONS .....	12
TEMPERATURE-SENSORS.....	13
ELEMENT-OVERTEMPERATURE-CONTROL .....	14
HEATER-ELEMENT-TCO.....	14
<b>SAFETY FEATURES .....</b>	<b>15</b>
<b>OPERATION .....</b>	<b>17</b>
START UP.....	17
SHUT-DOWN.....	17
DRAINING .....	17
<b>MAINTENANCE .....</b>	<b>18</b>
CLEANING.....	18
PREVENTATIVE MAINTENANCE .....	18
<b>SERVICE.....</b>	<b>19</b>
<b>WARRANTY.....</b>	<b>20</b>

## **INTRODUCTION:**

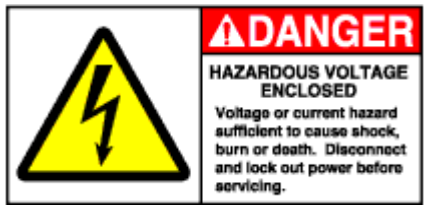
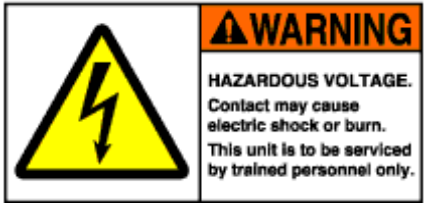
The following symbols and warning labels may appear on the unit and in the instruction manual. The table below provides an explanation of each one.

PICTORAL DESCRIPTION	DESCRIPTION
	<p><b>DANGER</b> indicates an imminently hazardous situation which, if not avoided, will result in death or serious injury. This signal word is to be limited to the most extreme situations.</p>
	<p><b>WARNING</b> indicates a potentially hazardous situation which, if not avoided, could result in death or serious injury.</p>
	<p><b>CAUTION</b> indicates a potentially hazardous situation which, if not avoided, may result in minor or moderate injury. It may also be used to alert against unsafe practices.</p>
	<p><b>DANGER: HAZARDOUS VOLTAGE ENCLOSED</b> Voltage or current hazard sufficient to cause shock, burn or death. Disconnect and lock out power before servicing.</p>
	<p><b>WARNING: HAZARDOUS VOLTAGE</b> Contact may cause electric shock or burn. This unit to be serviced by trained personnel only</p>
	<p><b>CAUTION: HOT SURFACE. DO NOT TOUCH</b> Heater column may be hot. Allow unit to cool before servicing.</p>
	<p><b>PROTECTIVE EARTH (GROUND)</b></p>

**Table 1: Warning Labels**

## **INTRODUCTION (CONTINUED):**

The SHX heater by Process Technology is designed to safely heat process solvents and isopropyl alcohol (IPA) through indirect contact instead of direct immersion. Wetted surfaces of the heater are PTFE fluoropolymer. It is designed for use in either single pass or multi-pass (recirculating) flow applications. The SHX is designed for operation in normal/non-classified environments.

### **Chemical Compatibility:**

The SHX is designed to heat solvents and aqueous process chemicals. Although PTFE fluoropolymer is resistant to most chemicals, there are some process chemistries with which the in-line heater should not be used. These include the following:

- Chemicals that degrade or decompose when heated.
- Halogenated solvents which attack the fluoropolymer material.



**CAUTION**

Do not use the SHX in line heater to heat incompatible chemistries. Incompatible materials will cause corrosion of the heating elements, process sensor, junction box or flange cover. Heater failure will result.

The SHX heater can withstand operation at a variety of temperature and pressure conditions. The maximum operating condition is 90°C, with maximum pressure ratings depending upon the connection sizes.



**CAUTION**

Safe operation of this heater requires the use of over-temperature control sensors, rated for the rating of the heater and with an approved safety switching device. Operating in excess of the maximum operating temperature (90°C) can result in conditions that can cause harm to operators and equipment.

### ***This Process Technology SHX Heater consists of:***

- \* *PTFE fluoropolymer fluid path*
- \* *No o-rings used in the fluid path*
- \* *Fluoropolymer insulated outer housing*
- \* *3 meter long wire leads*
- \* *(3) Element over-temperature sensors, type specified by model number*
- \* *(1) Thermal Cut-off Device (TCO)*
- \* *Fluid inlet and outlet connections, size and type specified by model number*
- \* *Purge gas inlet and outlet connections*

***The following equipment is recommended for safe operation of the SHX Heater, and must be customer-supplied.***

- \* *“Listed” process temperature controller with a liquid temperature sensor*
- \* *Liquid level sensor*
- \* *Purge gas*
- \* *Proper high-voltage power fusing and electrical disconnect switch*
- \* *Pump motor safety interlock circuit*
- \* *Ground fault circuit protection*
- \* *Leak detector*

## **INTRODUCTION (CONTINUED):**

### **FLUID HEATING INFORMATION:**

The SHX heater is designed to be used in either single pass or multi-pass (recirculating) flow applications. An application is defined as single pass when the solution will enter the heating chamber only once and must be heated to the desired temperature when it exits the heater. A multi-pass application is one in which the solution will be recirculated through the process and returned to the chamber heater, and may take several cycles through the heater to reach the desired temperature.

### **Single Pass Flow Application:**

For single pass applications, the SHX heater is designed to provide a specified temperature increase at a given flow rate. The formula below shows the maximum temperature increase ( $\Delta T$ ) that can be achieved for continuous flow conditions. Note: the formula below is based on the specific heat/gravity of water.

$$\text{Maximum temperature Rise (}^\circ\text{C)} = \frac{\text{Heater Power (kW)}}{\text{Flow Rate (LPM) } \times 0.07}$$

### **Multi-Pass Flow Application:**

For a multi-pass application, the SHX heater will elevate and maintain the temperature of a fixed volume of solution as it is circulated. Use the following formula to estimate the heat-up time for a volume of fluid in a multi-pass system. For estimating purposes, the specific heat and weight of water are often used. However, more accurate results will be achieved using the properties of the specific solution.

$$\text{Heat-up Time (minutes)} = \frac{\text{Volume (liters(L)) } \times \text{Density (kg/L)} \times \text{Temperature rise (}^\circ\text{C)} \times \text{Specific heat (J/kg } \times \text{ }^\circ\text{C)}}{\text{Heater Power (kW) } \times 60,000}$$

This formula does not take into account any heat losses to the surrounding environment. Other factors that must be considered include heat losses through plumbing and exposed process tank surfaces, and the load placed on the heater by the introduction of cold products and chemicals into process tanks.

## **HEATER SPECIFICATIONS:**

<b>Product</b>	SHX Series Heater	
<b>Approvals (Pending)</b>	Pending	
<b>Wattage</b>	6 kW	
<b>Voltage</b>	200V-480V, 50/60Hz, single phase or three phase	
<b>Dimensions:</b>	203.2mm wide x 561.3mm tall x 196.9mm deep	
<b>Wetted surfaces:</b>	PTFE fluoropolymer	
<b>Operating temperatures:</b> <b>Process inlet</b> <b>Process outlet</b>	Up to process outlet temperature Up to 90°C	
<b>Ambient Air Temperature</b>	-30°C (-22°F) to 60°C (140°F)	
<b>Flow Rate Range</b>	2-30 LPM. Higher flow rates possible based upon fluid pressure.	
<b>Pressure Rating at 90°C</b>	478 kPa (69 PSI)	
<b>Purge Gas</b>	Enclosure Purge inlet	Heater Purge Inlet
Flow Rate	0.5-5.7 LPM (1-12 SCFH)	0.5-1.2 LPM (1-2.5 SCFH)
Pressure	34 kPa (5 PSIG) max	103 kPa (15 PSIG) max
<b>Heater Core Over Temperature Sensors</b>	Qty (3) – type specified by model number see facilities drawing	
<b>Thermal Cut-Off Device (TCO)</b>	Qty (1) – rated at 150 VAC, 10-amps max. Trip temperature: 176°C.	

**Table 2: Heater Specifications**

## **FACILITY REQUIREMENTS:**

Before installing the SHX heater confirm the facility requirements listed below.

### **Space Requirements:**

The SHX heater is designed to be installed within a tool or bench near the process tank assembly. Allow adequate space in the tool for mounting of the heater. Also provide space to make necessary power and plumbing connections to the heater.



**CAUTION**

The heater should be installed in an area free from excessive chemical or liquid exposure. The electrical junction area must not be submerged or exposed to excessive splashing or high pressure spray.



**CAUTION**

The heater must be mounted vertically for proper operation. Do not mount the heater horizontally, or overheating problems may result.

### **Location:**

The SHX heater is designed to be located in non-classified, non-hazardous areas where exposure to process chemistry is likely. The heater's external components are constructed of materials similar to the wetted components, but is not designed to be externally submerged.

### **Mounting:**

The SHX heater is supplied with four holes for mounting. Ensure that the mounting location will adequately support the weight of the chamber, its supporting hardware and plumbing, and the fluid in the system. Refer to the facilities print of your heater for exact dimensions.

### **Plumbing Requirements:**

The SHX heater is supplied with tube fittings for the fluid inlet and outlet connections. Refer to the fitting manufacturer's specifications and instructions for proper fitting selection and installation requirements.

Plumbing must be compatible with process chemicals and temperatures.

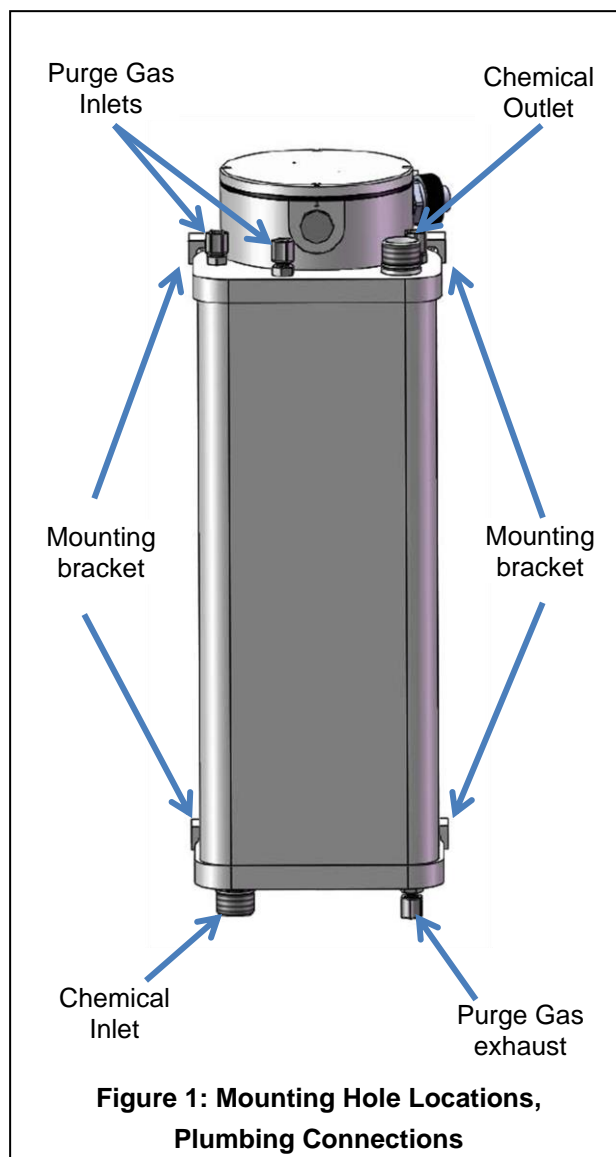

## **FACILITY REQUIREMENTS (Continued):**

### **PURGE GAS REQUIREMENTS:**

A source of purge gas, nitrogen (N<sub>2</sub>) is required for the heater purge system. There are two inlet fittings and two exhaust fittings for the purge gas. This heater uses 6 mm (1/4-in) compression fittings as the purge gas inlet and outlet connections. The purge gas should be applied to the heater whenever there is fluid inside the unit.

**The purge gas flow rate for each circuit must be regulated to a flow rate of 0.5-1 l/min (1-2 SCFH).**

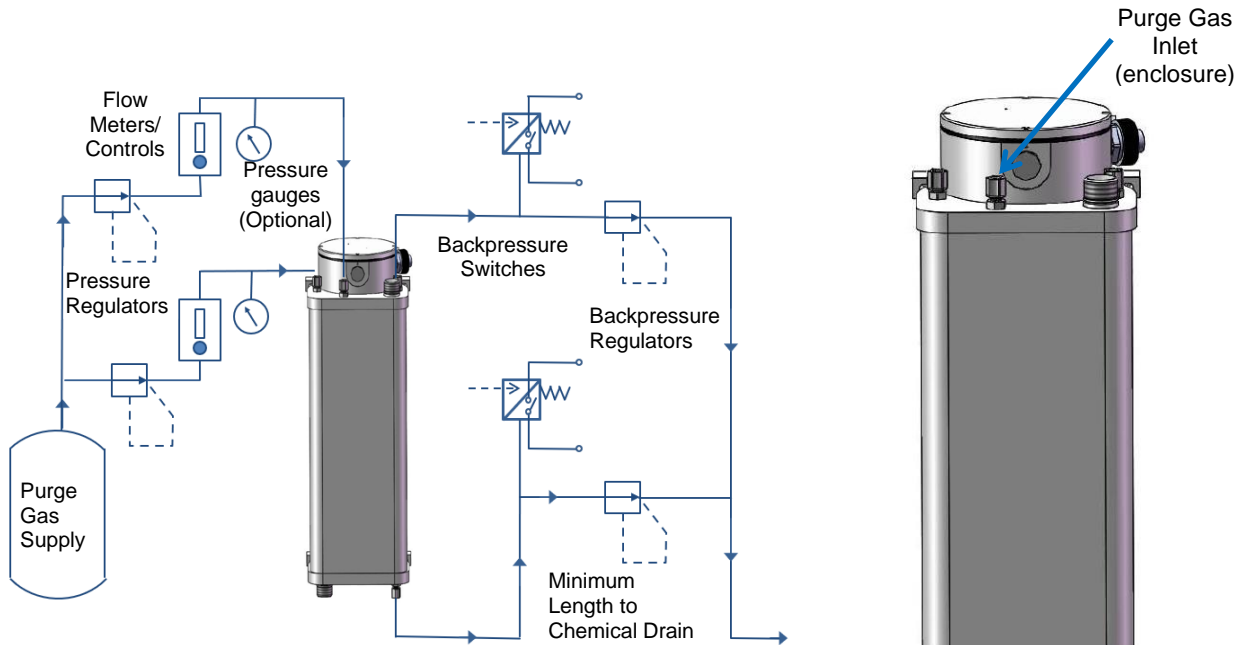

**Figure 2: Purge Gas Plumbing Schematic**

**Figure 3: Purge Gas Connections (enclosure area)**

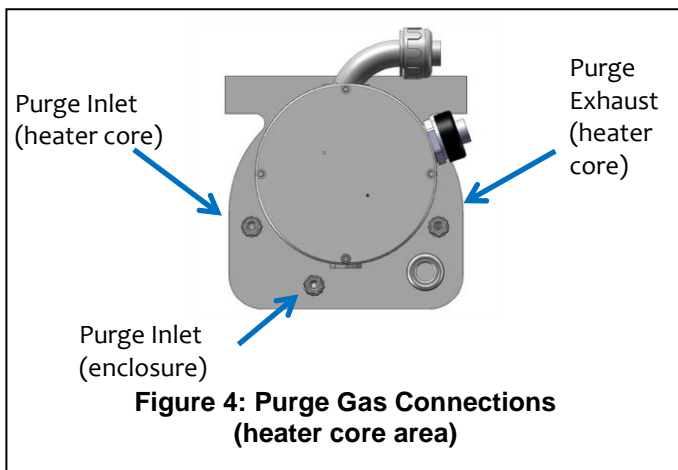

**Figure 4: Purge Gas Connections (heater core area)**



Do not exceed pure gas pressure of 103 kPa on the heater core connection, or 34 kPa on the enclosure connection. Irreparable damage to the heater may result.



## **FACILITY REQUIREMENTS (Continued):**

### **Electrical Requirements:**

The SHX heater comes with power and sensor wires which exit the heater at the wire conduit fitting shown in the figure to the right. The electrical system for this heater must comply with all local requirements, including ANSI/NFPA70 in the United States CAS 22.2 for Canada. Verify that the electrical service is rated and fused for the required amperage draw.

Ensure protective measures used for isolation and switching comply with IEC 60364-4.

**Over-current Protection:** If using circuit breakers, ensure use of a circuit breaker suitable for isolation and in compliance with IEC 60947-2. If using fuses, select in accordance with IEC 60269-2 combined with a magnetic contactor in accordance with IEC 60947-4-1.

Ensure protective measures for over-current in electrical wiring is in accordance with IEC 60364-4-43 and IEC 60364-4-473.

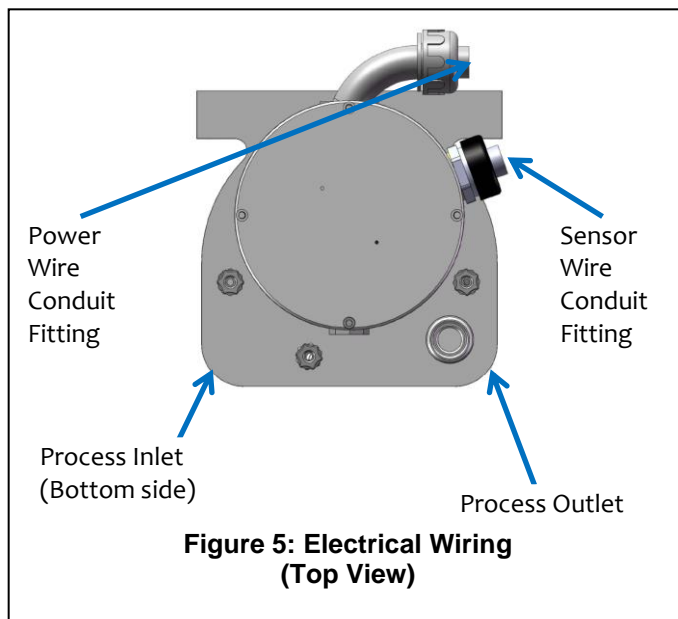

**CAUTION**

Do not exceed the rated voltage. Irreparable damage to the heater will result.

**NOTE:** Ensure electrical power fusing and disconnects meet local jurisdictional requirements. Fuse ratings noted in this document are for reference only. Ensure external electrical components comply with local requirements before operating this unit.

### **Temperature Controller:**

The use of a listed temperature controller is required. The listed temperature controller should include a process temperature sensor to measure the fluid temperature exiting the heater and the ability to turn the heater off to maintain the desired outlet temperature setting. Temperature control and external process temperature sensor not provided by Process Technology.

## **FACILITY REQUIREMENTS (Continued):**

### **Liquid level sensor:**

The use of a process-fluid sensor is recommended. The heater can be used with a capacitance-type Liquid level sensor connected to the outlet tube of the heater. The sensor monitors the presence of solution in the outlet piping to ensure that the heat exchanger is filled with process solution during operation.

The Liquid level sensor must be wired into the heater control circuitry in such a manner, as to shut the heater off when there is no liquid in the outlet tube of the heater. Liquid Level sensor is not provided by Process Technology. The sensor will need to be a latching circuit that will disengage the heater when fluid is not present.



Do not energize the heater when the liquid is not flowing or unit is empty. Irreparable damage to the unit will result.

## **INSTALLATION:**

Before installation, carefully read this entire section.

### **Uncrating and Inspection:**

- 1) Remove the Heater assembly from its shipping container.
- 2) Remove any protective packaging material and discard.
- 3) Inspect unit for any apparent physical damage.

### **Mounting Heater:**

Reference the provided facility drawing for the location and dimensions of the mounting holes.

- 1) Ensure that the chamber is mounted vertically with the electrical fittings and plumbing connections at the top.
- 2) Securely bolt chamber assembly in the desired location.

## **INSTALLATION (CONTINUED):**

### **Process Fluid Inlet and Outlet Connections:**

Super 300 Type Pillar™ process fluid line connections use a “gauge ring” (see figure), which is used to determine the proper tightness of the fitting connections. Check the facilities print for the connections supplied with this unit.

- 1) Remove the protective plastic caps from the Pillar fittings on the Inlet and Outlet piping of the heater assembly.
- 2) Install appropriately sized Super 300 Type Pillar “gauge ring”.
- 3) Connect properly sleeved tubing to the Inlet and Outlet of the heater chamber assembly.
- 4) Tighten the Pillar fitting nut until the bosses on the union nut make contact with the gauge ring and pulls the blade. A clicking sound will be heard at this point.

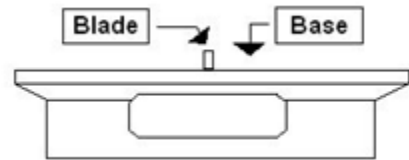

**Figure 6: Super 300 Type Pillar gauge ring**

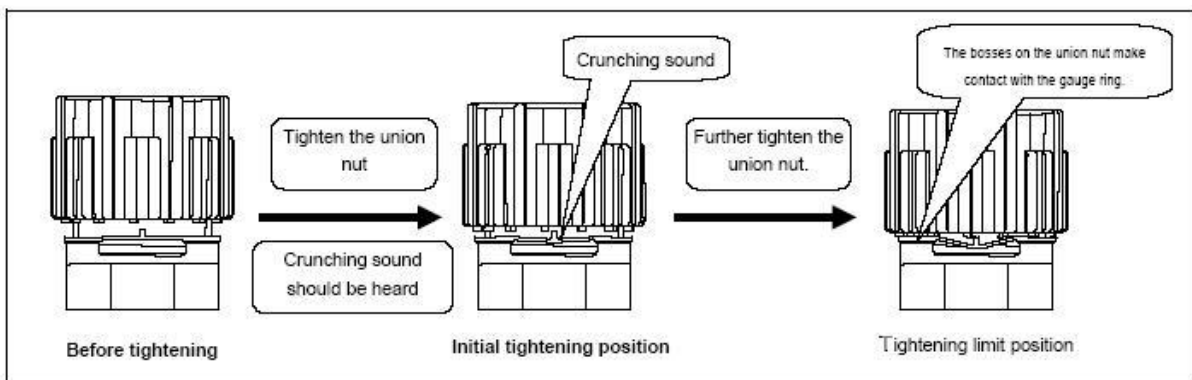

**Figure 7: Super 300 Type Pillar connection procedure**

## **INSTALLATION (CONTINUED):**

### **Flared tube inlet/outlet plumbing connections:**

- 1) Remove the protective plastic caps from the Flared fittings on the Inlet and Outlet piping of the heater assembly.
- 2) Connect properly flared tubing to the Inlet and Outlet of the heater chamber assembly.
- 3) Tighten the fitting nuts until fitting nut contacts the flared tubing. Tighten an additional ¼ turn. Then torque, fitting nut to the minimum required torque value. See **Table 2** for proper values.

<b>Fitting Size</b>	<b>Torque Value</b>
12mm (½-in) Flared	1.24 Newton-meter (11in-lbs).
19mm (¾-in) Flared	1.58 Newton-meter (14in-lbs).

**Table 2: Heater Specifications**



### **CAUTION**

Ensure Process Fluid Line connections are at 30°C or below before tightening of the fittings. Tightening the fitting at higher temperatures will result in damage to the tubing, and to the liquid seal.

### **Purge Gas Connections:**

The purge gas connections are located on the top and bottom of the unit. There are two inlet and two outlet fittings. Refer to figures 3 and 4 for the locations. The standard connections are 6 mm (¼-in) compression fittings.

- 1) Using 6 mm (¼-in) OD tubing, connect the purge INLET to a pressure regulator connected to the purge gas supply. Hand tighten the fitting cap until seated. Tighten an additional ¼ turn.
- 2) Using 6 mm (¼-in) OD tubing, connect the Heater Purge Exhaust (labeled OUTLET) to an approved exhaust area. Hand tighten the fitting cap until seated. Tighten an additional ¼ turn.



### **CAUTION**

The exhaust gas should be properly vented as chemical exhaust.

## **INSTALLATION (CONTINUED):**

### **Electrical Connections:**

#### **Main Power:**

Power leads on the SHX heater can consist of (3-6) three or six black power leads, and (1) one green ground lead. Please see the facilities or electrical schematic for the configuration. All electrical connections and safety devices must comply with local electrical code guidelines.

- 1) Refer to the model number label for the power requirements for this heater.
- 2) Fuse the incoming power supply lines for the rated amperage using an approved electrical disconnect. The electrical disconnect must meet the following minimum requirements:
  - Appropriate voltage and amperage ratings for the specific heating system. Verify that all fused electrical disconnects meet jurisdictional requirements.
  - For safety of service and maintenance personnel, this electrical disconnect must be located within sight of the equipment.
- 3) Ensure that all services are off before making connections (electrical, liquids, and gas). Lockout and Tagout as appropriate. Use only approved and properly rated wire, conduit and connectors.
- 4) Connect heater power leads to an electrical disconnect device in the customer supplied controller. This electrical disconnect must have the proper electrical rating necessary for the equipment.
- 5) Connect heater ground lead to proper grounding point.

#### **Electrical Conduit Fitting:**

The following instructions pertain to the fitting for the end of the electrical conduit.

- 1) Cut the end of the conduit square.
- 2) Apply compression nut over the end of the conduit.
- 3) Apply connector ferrule over the end of the conduit.
- 4) Place threaded insert into the end of the conduit.
- 5) Place conduit with insert, ferrule and nut into the connector body until the insert sits firmly in the bottom of the connector body interior.
- 6) Slip the connector ferrule along the conduit until it is seated against the connector body.
- 7) Hand-tighten the compression nut firmly onto the connector body threads.
- 8) Place the sealing ring onto the connector body.
- 9) Insert assembly into a 23mm (7/8-inch) diameter (or appropriately sized) hole in panel or box opening.
- 10) Secure the assembled connector into the panel or box using the locknut, making sure that the sealing ring is between the connector bod and the panel or box.

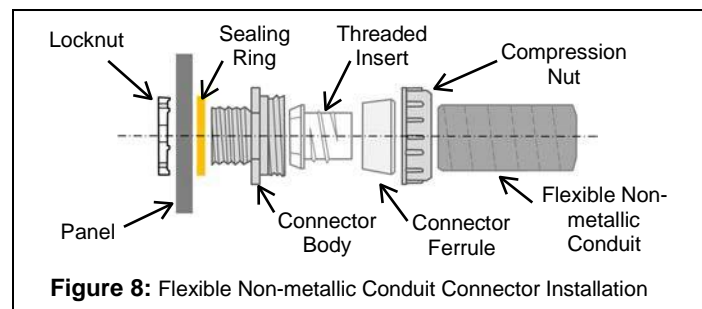

## **INSTALLATION (CONTINUED):**

### **Over-temperature sensors and over-temperature control:**

The SHX heater is supplied with (3) three temperature monitoring sensors and (1) one TCO (temperature cut off device) to ensure safe internal operating temperatures. These sensors must be installed into a customer-supplied control package to protect the equipment from accidental damage and to ensure operator safety. The element over temperature devices need to be connected to a momentary/latching control devices to disengage heater in the event of an over temperature situation. TC1 or RTD1 can be connected to a momentary that will interrupt the heater output momentarily. The other 2 over temperature sensors are required to be connected to a latching circuit that will disengage the heater output completely. The TCO device will need to be a latching control devices to disengage the heater output in the event of an over temperature situation.

Devices Include:

- Three (3) Element Over-temperature Sensors
- One (1) Heater Element TCO (Thermal Cut-Off) Device

**NOTE:** Failure to use the supplied over-temperature control devices for their intended purposes may void all or part of the equipment warranty. Consult factory for technical assistance.

## **INSTALLATION (CONTINUED):**

### **Over-temperature Sensor:**

The Heater Over-temperature Control Sensors measures the operating temperature of the heater element. This heater is supplied with three sensors for element temperature sensing. The sensors are positioned so that each electrical phase is monitored. Should an electrical phase loss occur and two sections of the heater reduce or produce no heat output, the other sensors will still detect any over-temperature condition. If only relying on one sensor for over-temperature control, it is very important to monitor the sensor labeled **TC1** or **RTD1**.

The element over temperature can be limited to not exceed 200°C( momentary alarm)during operation with an absolute DO NOT exceed of 210°C( Latching alarm) or irreparable damage may occur. If only 1 over temperature device is used then it will need to be connected to a latching circuit. That latching circuit should interrupt the operation of the control circuit and interrupt the operation of the heater.

The element operating temperature will vary based on variables such as the flow rate and the liquid temperature. As such, set the respective element over-temperature control 80°C above the desired heating set point of the chemical.



### **CAUTION**

These sensors **MUST** be connected to an ELV circuit.  
These sensors **MUST** be connected to an approved safety switching device.

### **Heater Core TCO (Thermal Cut-Off):**

The Heater core TCO is a Bi-metallic resettable device which opens when it reaches a preset temperature. This device must be connected to latching circuit to interrupt the operation of the control circuit if it is tripped by an element over-temperature condition.

The TCO device is set to open at 176°C.



### **CAUTION**

Do not connect the TCO in series with the heating element/main load. It is designed to be wired into the heater's control circuit, connected in series with the coil of the magnetic contactor for the main load. Protection of the circuit shall be done with a fuse, according to IEC or EN 60691 or a circuit breaker according to IEC 60947-2.

## SAFETY FEATURES:

### Safety System Network:

This SHX heater is supplied without a Temperature Control package. Certain safety interlocks must be incorporated into the control package to prevent damage to the heater and ensure the safety of the operator. Each interlock circuit monitors a critical operating parameter of the heater. The control system is designed so that if a "fault condition" is detected by one of the sensors, the power to the heating element is disengaged. The shutdown mechanism may be momentary or latching; refer to table below.

	Do not energize the heater when the liquid is not flowing through the unit or chamber is empty. Irreparable damage to the unit will result.
---	---

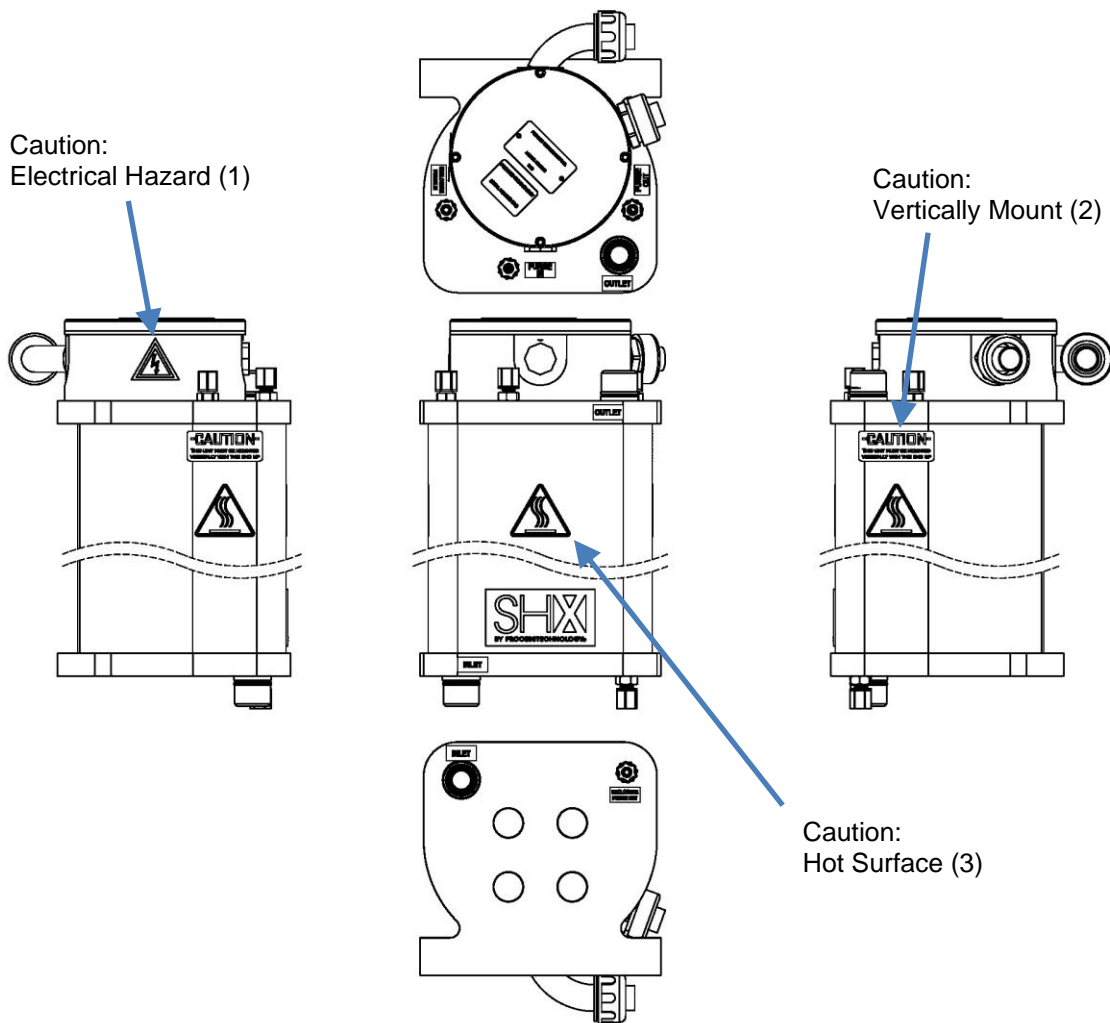

**Figure 9:** Flexible Non-metallic Conduit Connector Installation



<b>Safety device</b>	<b>Operation</b>	<b>Type of Shutdown</b>
Pump Interlock (Customer-Supplied)	Monitors condition of pump, disrupts power to heater when pump is not in operation.	latching
Liquid Level Control (Customer Supplied)	Monitors presence of adequate fluid in heater vessel, disrupts power to heater if fluid is not present in the outlet piping.	latching
Process Temperature Control Device (Customer Supplied)	Monitors temperature of fluid, disrupts power to heater when temperature rises above set point.	momentary
Process Over-Temperature Control Device (Customer Supplied)	Monitors temperature of fluid, disrupts power to heater when temperature rises above set point.	latching
Heater Element Over-Temperature Control Device (Sensors Included with Heater) (Control Customer Supplied)	Monitors temperature of heating element, disrupts power to heater when temperature rises above set point. The set point should be no lower than 80°C above the desired outlet control set point. Element temperature limited to 200°C with a not to exceed 210°C.	momentary/ latching
Heater Core TCO (Included)	Monitors temperature of heater core and disrupts power to heater when temperature rises above preset temperature of TCO.	latching
Purge gas interlock (Customer supplied)	Monitors the purge gas back pressure switch, disrupts power to the heater when no purge gas pressure is detected.	momentary/ latching
Leak detection (Customer supplied)	Monitors presence of liquid outside of the unit, disrupts power to heater if fluid is detected.	latching

**Table 4: Safety System Network**

## **OPERATION:**

### **Start Up Procedure:**

- 1) Start process fluid flow. Allow solution to flow for several minutes to remove any air from the heat exchanger.
- 2) Turn on the purge gas supply. Verify the flow rate is at the recommended value.
- 3) Turn on the main power to the system.
- 4) Turn on the control module.
- 5) Verify proper reading of the process temperature.
- 6) Engage the control system's safety relay, if applicable.
- 7) Turn on the heater.

### **Shut-Down Procedure:**

- 1) Turn OFF electrical power to the heater.
- 2) Allow heater to cool. The heater may be damaged if the heater is allowed to operate in air or if residual heat is not allowed to dissipate before draining. Before the chamber is drained, the outlet temperature must be allowed to cool to within 1°C of the inlet temperature. Then, wait an additional 10 minutes.
- 3) Turn OFF process fluid flow through the heater.
- 4) Turn OFF process controller.
- 5) Turn OFF the purge gas.
- 6) Turn OFF Main Electrical Power.
- 7) For extended shut down periods, drain the system.

### **Draining Procedure:**

There is no drain fitting provided with the SHX heater. If draining the unit is necessary, the heater will need to be disconnected from the plumbing connections and inverted to allow the liquid to drain out of the heat exchanger.



Small amounts of process chemistry may remain in the unit after draining. The unit should be flushed with hot water then drained several times to eliminate any residual chemistry.

## **MAINTENANCE:**

### **Cleaning:**

This Process Technology SHX heater was cleaned before shipment. However, cleaning is typically required to remove any contaminants remaining after installation. The times required for cleaning of the system are dependent on DI water quality, flow rates, and installation techniques, and will vary. Additional steps may be indicated for some applications.

- 1) Operate the SHX heater at ambient temperature for several hours, overnight if possible, at a minimum flow rate of 2 lpm (0.5 gpm).
- 2) Operate the SHX heater for several hours, overnight if possible, at the maximum DI Water flow rate that will allow an exit temperature at or above 70°C to be maintained.

**NOTE:** Components of the heater are constructed of PTFE fluoropolymer. Verify chemical compatibility before sanitizing the unit.

### **Preventative Maintenance of the Heater Chamber:**

The Process Technology SHX heater requires minimal preventive maintenance.

The process inlet/outlet fittings should be checked for leaks every Six Months or at the interval recommended by the fitting manufacturer – whichever comes first.

## **SERVICE:**

Process Technology supports its product line with a strong technical support and field service program. If your SHX heater fails to perform properly, follow the outlined steps for resolution.



### **CAUTION**

There are no user serviceable or replaceable parts inside the heater. Do not attempt any field repairs as this will void the warranty.

- 1) Verify connections and program parameters.
- 2) Contact the Process Technology Technical Service Group. When placing this call, please have available the model number and serial number of the unit (located on the system tag), information about the application of the equipment, and information regarding the chemical constituents of the process fluid. The Service Technician will evaluate the situation and determine a course of action for troubleshooting and repair.
- 3) If the Technician determines that the unit should be returned to the factory for evaluation, a Returned Materials Authorization (RMA) Number will be issued. A return will not be accepted without prior authorization.

To protect the safety of Process Technology's workers and any others that may come in contact with the SHX heater in the course of transport, evaluation, and repair, Process Technology requires that these practices be followed in returning the equipment to the factory:

- 1) Rinse the equipment until it is free of any chemical residuals. This is required for safe transport and handling of the equipment.
- 2) Wrap the unit in plastic and secure. Make sure that it does not leak. (Process Technology is not responsible for damage caused by leakage during shipping.)
- 3) Carefully package the unit for shipment.
- 4) Indicate the type of chemical that was in use at the time of failure. Include this information on the packing slip or place the information on the outside of the box. Process Technology will not risk exposure of its personnel to unknown chemicals. A return will not be evaluated until chemical information is received.

**NOTE:** It is possible that process fluid residues may remain even after thorough rinsing. Chemical information must be included even when a unit is believed to be clean so that Process Technology may protect its workers from exposure to these residues.

- 5) Clearly mark the outside of the box with the RMA number.
- 6) Ship the component prepaid to Process Technology.

Upon receipt of a returned unit, Process Technology will follow these steps:

- 1) The equipment will be carefully unpacked, inspected and cleaned, and an evaluation will be done.
- 2) A Process Technology technician will contact you with information regarding the scope of work to be performed, the cost, and the amount of time needed.
- 3) After a purchase order and authorization to perform the repair are received, the repairs will be completed and the unit returned.

## **WARRANTY:**

All PROCESS TECHNOLOGY equipment, heaters and controls have been carefully inspected before shipping and are warranted to be free from defects in workmanship and materials for a period of one year from date of purchase on a pro-rated basis. At its option, PROCESS TECHNOLOGY will repair or replace any defects that are exhibited under proper and normal use. PROCESS TECHNOLOGY disclaims any responsibility for misuse, misapplication, negligence or improper installation of equipment, tempering or other operating conditions that are beyond its control (such as excessively high or low purge gas supply pressure). PROCESS TECHNOLOGY makes no warranty or representation regarding the fitness for use or the application of its products by the customer.

All products and components not manufactured by PROCESS TECHNOLOGY will carry the original manufacturer's warranty, copies of which are available upon request. PROCESS TECHNOLOGY makes no warranty or representation, expressed or implied, with respect to the products not manufactured by PROCESS TECHNOLOGY.

Products must be installed and maintained in accordance with PROCESS TECHNOLOGY instructions.

PROCESS TECHNOLOGY is not liable for labor costs incurred in removal, reinstallation, or unauthorized repair of the product or for damage of any type including incidental or consequential damage.

PROCESS TECHNOLOGY neither assumes nor authorizes any representative of PROCESS TECHNOLOGY or any other person to assume for it any other liabilities in connection with the sale of the products. This warranty may not be verbally changed or modified by any representative of PROCESS TECHNOLOGY.

### **Shipping Damages:**

Claims against freight carriers for damage in transit must be filed by the customer at the time of delivery or as soon as possible.

### **Returns:**

No product shall be returned to PROCESS TECHNOLOGY without first obtaining a return material authorization (RMA) number from a PROCESS TECHNOLOGY representative. All returns must be freight prepaid. Freight collect or shipments without authorization will be refused.

### **Information:**

PROCESS TECHNOLOGY will endeavor to furnish such advice as it may be able to supply with reference to the use by buyer of any material purchased, but PROCESS TECHNOLOGY makes no guarantees and assumes no obligation or liability for advice given verbally or in print or the results obtained. Buyer assumes all risk and liability that may result from the use of any material, whether used by itself or in combination with other products. No suggestion for product use shall be construed as a recommendation for its use in infringement on any existing patent.

### **Conflict Between Documents:**

Acceptance of this offer is expressly conditioned upon agreement to all terms and conditions contained herein. In the event of a conflict between the terms and conditions of purchaser's purchase order, and PROCESS TECHNOLOGY's terms and conditions, proposal or offer, the latter shall govern.

# Page Left Blank